

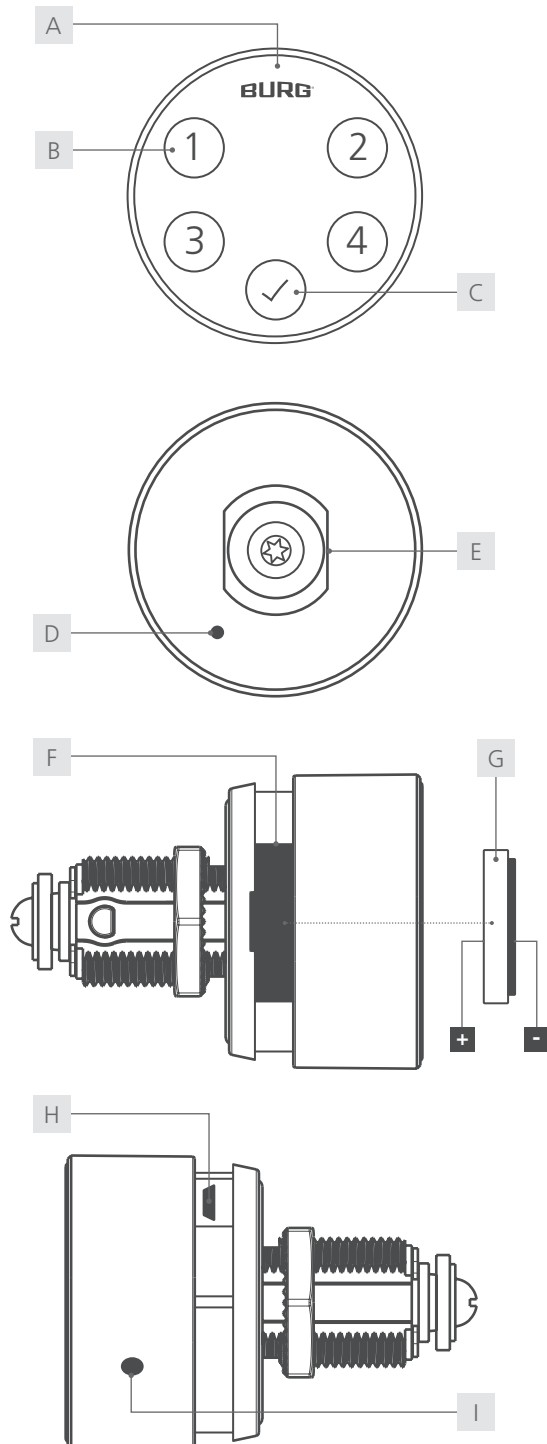

Intro.Code  
Operating Manual

## Intro.Code



- |                    |                       |
|--------------------|-----------------------|
| A LED              | B number key          |
| C confirmation key | D reset hole          |
| E stator           | F battery compartment |
| G battery          | H micro USB port      |
| I closure hole     |                       |

## Content

Introduction.....	2
General.....	2
Technical data.....	3
Scope of delivery.....	3
Optional accessories.....	3
Default settings.....	3
Features.....	3
Product dimensions.....	3
Functional description.....	4
Configuration.....	4 - 5
Operation.....	5
Emergency power supply.....	6
Battery replacement.....	6
Reset to default settings.....	6
Disposal and battery note.....	6

## Introduction

The electronic code lock **Intro.Code** is the entry into a new dimension of digital security for steel and wooden furniture. With its simple operation by numerical code, the lock makes everyday life easier and impresses with its high-quality materials. Especially the solid metal knob convinces with its noble matt chrome surface. The lock adapts to any installation situation, thanks to common mounting holes and replaceable cam.

**Important: Please observe all warnings and read through the entire operating instructions before you begin with the configuration.**

## General

The latest version of this guide is available at:  
[www.burg.de](http://www.burg.de)

Scan here for instruction video:



## Data Sheet

### Front view



### Back view



#### Technical Data

Dimension	Ø 43,3 mm
Battery	VARTA <sup>1</sup> CR2450 (1x)
Locking cycles <sup>1</sup>	3,000
Working temperature	-20° C to 55° C rel. humidity: 10% - 85%
Mode	Multi-user mode, Private mode
Material	Housing: Zamak Front cap: plastic Cam: steel
Mounting dimension	16 mm x 19 mm
Lock attachment	M19 nut (1x)
Locking direction	Left (90°), door hinge: DIN right Right (90°), door hinge: DIN left
Cam type	B
Max. door thickness	18 mm
Code length	4 to 15 digits
User code (default)	1234
Master code (default)	4321
No. of master codes	max. 1
No. of user codes	max. 1

#### Scope of Delivery

- 1x locking system
- 1x cam fixing screw<sup>2</sup> M4 x 8 mm
- 1x washer 12 mm (DIN 9021 M4)
- 1x M19 nut
- cam type B

#### for single packaging:

- 1x length 53 mm, without crank (1-36 RIH-501 G)
- 1x length 40 mm, crank 3 mm (1-36 RIH-514 K)
- 1x length 40 mm, cranking 6 mm (1-36 RIH-515 K)

#### for industry packaging: order related

<sup>1</sup> The lock is approved for VARTA brand batteries. The use of other batteries may result in a reduced number of possible locking cycles.

<sup>2</sup> The use of a screw with a different length may cause damage to the lock.

#### Optional Accessories

- opening and reset pin
- anti-twist protection (W-MSZ-01)

#### Default Settings

Mode	Multi-user mode <sup>3</sup>
Fake code function	Off

#### Features

- ergonomic handling and high-quality design
- external battery change
- easy to retrofit, e.g. for replacement of mechanical cam locks
- latch adjustable in 45° steps
- emergency power supply via micro USB port

#### Product Dimensions

##### Side view

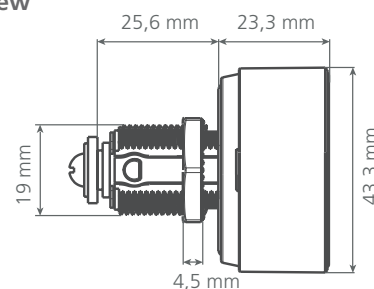

##### Top view

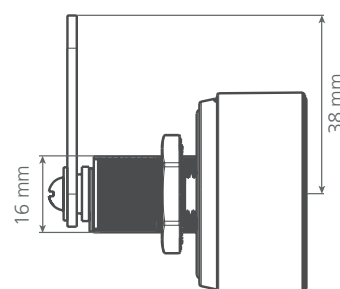

<sup>3</sup> Applies from versions EIRR-007 to EIRR-010. Private Mode applies to earlier versions.

## Functional Description

### Mode: Fixed Assigned Authorization (private mode)

In this mode, a user code is preset with which the lock can be operated. The lock unlocks when the stored user code is entered. A code that has not been saved is rejected by the lock. This mode is suitable for user groups where the user rights are not to change permanently, e.g. for an office cabinet.

### Mode: Multi-User Authorization (multi-user mode)

In this mode, user codes are only valid for a single locking operation. The lock locks when a user code is entered and unlocks when the same code is entered. When unlocking, this code is deleted from the lock so that a new user code can be used. The lock remains in the open state until a new user code is used for locking. This mode is suitable for changing user groups where the locker is only used temporarily or once, e.g. in a sports facility.

### Master code

The master code authorizes the programming of the lock. In addition, the master code can unlock the lock independently of the set mode (emergency opening). In multi-user mode, the code used for locking is deleted after the master code is entered.

*Note: We recommend programming a private master code before putting the lock into operation.*

### LED Locking Indication

If the lock is in the locked state, the green LED flashes briefly every three seconds.

### Battery Warning

If the battery voltage falls below a certain level, the LED lights up briefly when the code is entered. If the voltage falls into the critical range, the lock can no longer be operated.

### Block Mode

If an incorrect code is entered four times in succession, the lock locks for 60 seconds. During this time, the lock rejects any code entry.







### Fake Code Function

To prevent the user code from being read when it is entered, the fake code function can be activated. In this case, a non-valid code (fake code) is entered before or after the correct code is entered. This code may have a maximum of 15 digits.

## Configuration







### 1 Change the Mode

#### a) Multi-user mode (default)

1. Enter master code and press . A longer beep and the green LED confirm the successful process.
2. Directly press  and hold the button for 2 seconds. The green LED starts flashing.
3. Press  again. Enter the numbers  and .
4. Confirm with . A longer beep confirms the successful process.

*Note: Changing the mode does not reset the lock to the default setting.*



#### b) Private Mode

1. Enter master code and press . A longer beep and the green LED confirm the successful process.
2. Directly press  and hold the button for 2 seconds. The green LED starts flashing.
3. Press  again. Enter the numbers  and .
4. Confirm with . A longer beep confirms the successful process.

*Note: Changing the mode does not reset the lock to the default setting.*

### 2 Set the Master Code and User Code

#### a) Master code

1. Enter current master code and press . A longer beep and the green LED confirm the successful process.
2. Directly press  and hold the button for 2 seconds. The green LED starts flashing.
3. Enter new master code and confirm with . A longer beep and the green LED confirm the successful process.

*Note: User code and master code must not be the same. Only one master code can be stored. During the storage process, the old master code is overwritten.*

**b) User Code (Private Mode)**

1. Enter current user code and press ✓. A longer beep and the green LED confirm the successful process.
2. Directly press ✓ and hold the button for 2 seconds. The green LED starts flashing.
3. Enter new user code and confirm with ✓. A longer beep and the green LED confirm the successful process.

*Note: User code and master code must not be the same. Only one master code can be stored. During the storage process, the old master code is overwritten.*

**c) Reset User Code**

To reset the user code, the master code is entered. When the master code is entered, the lock unlocks.

Multi-user mode: the active user code is deleted.

Private mode: the active user code is reset to factory setting ( 1-2-3-4).

**3 Activate / Deactivate Fake Code Function**

1. Enter master code and press ✓. A longer beep and the green LED confirm the successful process.
2. Directly press ✓ and hold the button for 2 seconds. The green LED starts flashing.
3. Press ✓ again.  
To *activate*, enter the numbers ④ and ②.  
To *deactivate*, enter the numbers ④ and ①.
4. Confirm with ✓. A longer beep confirms the successful process.

**b) Lock**

The lock locks automatically within 4 seconds. The red LED flashes briefly. To close, turn the knob back to the starting position until it engages.

**2 Mutli User Mode****a) Lock**

1. Close the door and turn the knob back to its original position.
2. Press ✓. The green LED starts flashing.
3. Enter user code and press ✓. A longer beep and the red LED confirm the successful process.

**b) Unlock**

1. Enter user code and press ✓. A longer beep and the green LED confirm the successful process.
2. Turn the knop to the open position within 3 seconds.

*Note: The lock signals an incorrect code entry with three consecutive beeps.*

**3 Unlock via Master Code**

1. Enter master code and press ✓. A longer beep and the green LED confirm the successful process.

Multi-user mode: the active user code is deleted.

Private mode: the active user code is reset to factory setting ( 1-2-3-4).

*Note: The lock signals an incorrect master code entry with three consecutive beeps.*

**Operation****1 Private Mode****a) Unlock**

1. Enter user code and press ✓. A longer beep and the green LED confirm the successful process.
2. Turn the knop to the open position within 3 seconds.

*Note: The lock signals an incorrect code entry with three consecutive beeps.*

## Emergency Power Supply

If the battery voltage is insufficient, the locking system can be connected to an external power supply (e.g. power supply unit, notebook or power bank) via the **micro-USB** connection using a micro-USB cable. The locking system can then be operated normally.

*Note: We recommend to replace the batteries at the first battery warning.*

## Battery Replacement

1. Press the reset pin into the closure hole on the side of the lock. Turn the housing slightly to the left and pull it forward.

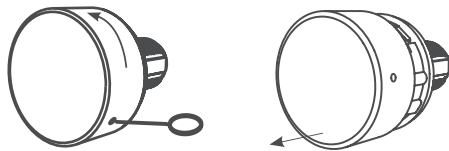

2. Remove the battery compartment and replace the battery according to the symbols (+ / -) (Fig. p. 2).

*Note: The surface of the battery must be free of residues and fingerprints, otherwise malfunctions may occur. If the surface is dirty, it must be cleaned with a dry cloth.*

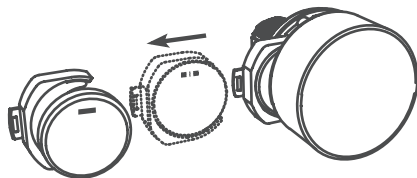

3. Replace the battery compartment, slide the housing back onto the lock and turn until it clicks into place.

*Note: The lock is approved for VARTA brand batteries. The use of other batteries may result in a reduced number of possible locking cycles.*

## Reset to Default Settings

To reset the lock, press the reset pin briefly into the reset hole on the back. All stored data will be deleted from the lock.

**Important: The reset hole can only be operated in the disassembled state.**

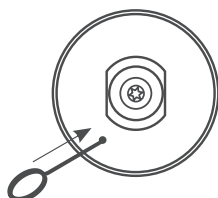

## Disposal and Battery Note

EU Directive 2012/19/EU regulates the proper take-back, treatment and recycling of used electronic equipment.

Every consumer is required by law to dispose of batteries, accumulators or electrical and electronic equipment („waste equipment“) powered by batteries or accumulators separately from household waste, as they contain harmful substances and valuable resources. Disposal can be done at a collection or take-back point approved for this purpose, e.g. a local recycling center. Waste equipment, batteries or rechargeable batteries are accepted there free of charge and recycled in an environmentally friendly and resource-saving manner.

Waste equipment, used batteries or rechargeable batteries can also be returned to us. The return must be sufficiently stamped to the address below.

The following symbol on the waste electrical equipment, batteries or accumulators indicates that they must not be disposed of with household waste:



### Caution when using batteries!

The battery may explode or release flammable gases if it is mis-handled, destroyed, or the wrong type of battery is used. Do not recharge the battery, disassemble it, expose it to extremely high temperatures or throw it into a fire.

On batteries containing harmful substances, you will find indications in the form of abbreviations for the ingredients cadmium (Cd), mercury (Hg) and lead (Pb) in each case.

### BURG Lüling GmbH & Co. KG

Volmarsteiner Str. 52  
58089 Hagen (Germany)  
+49(0)2335 6308-0

info@burg.de  
www.burg.de