

HAGS

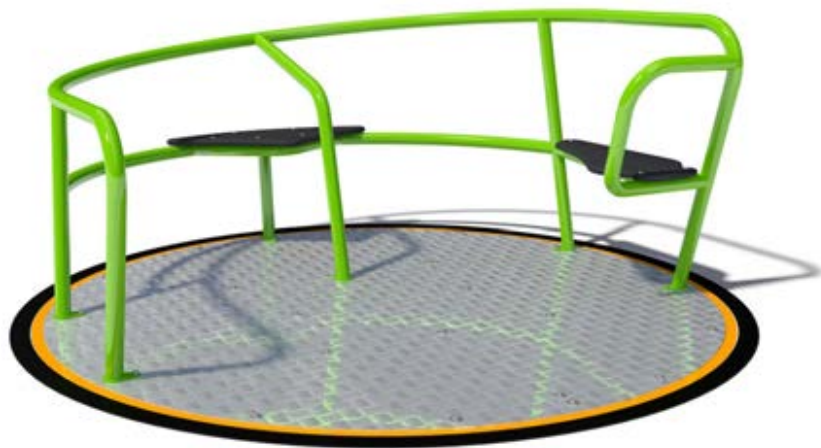

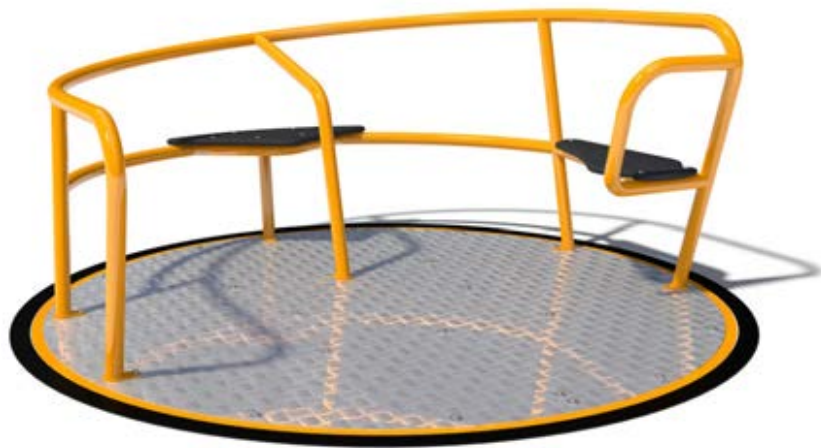

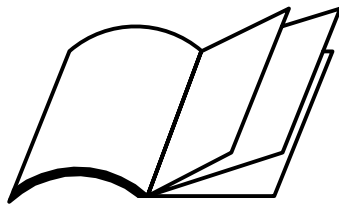

SPINMEE

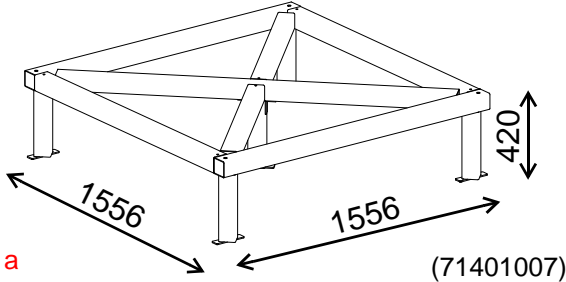
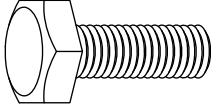

CAR-SP2

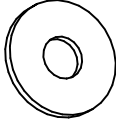
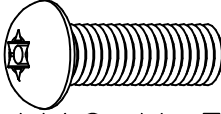
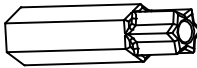
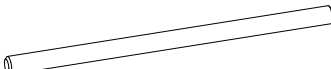

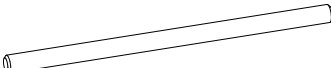

Section 1:

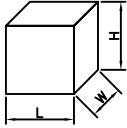
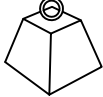
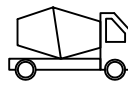
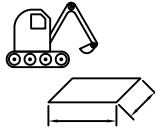
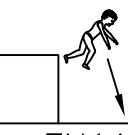
ITEM	REF	CAR-SP2	QTY	kg
1.1	71401001	 <p>a (71401007)</p>	1	86.50
1.2	10231030	 <p>M10 X 30</p>	4	0.029
1.3	10321000	 <p>M10</p>	4	0.012
1.4	10309999	 <p>M10 11X30X2.5</p>	12	0.002
1.5	10121030	 <p>M10 X 30</p>	4	0.024
1.6	10121000	 <p>T45 M10</p>	1	-
1.7	419305	 <p>Ø20 X 400</p>   <p>18 Appendix C (STEP 3)</p>	1	1.00
1.8	71403008	 <p>Ø8 X 150</p>   <p>19 Appendix C (STEP 6)</p>	1	0.06

	 LxWxH (m)	 kg	 m ³	 m	 ≥EN1176	 x 2 = T
CAR-SP2	Ø2.040 x 1.439	367.0	0.60	6.00 x 6.00	1.00m	T = 12

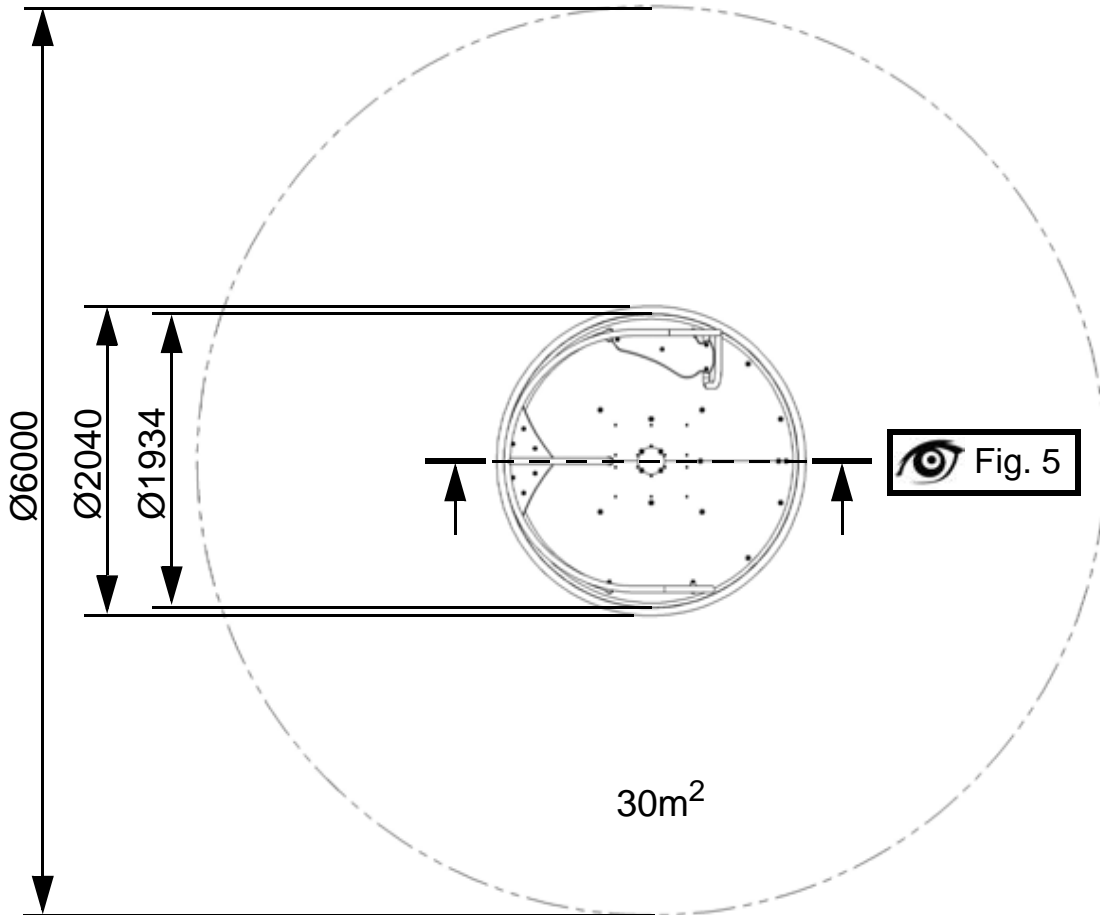
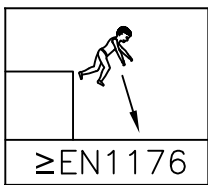

Fig. 3

 **144**
TYPE 3



1 m

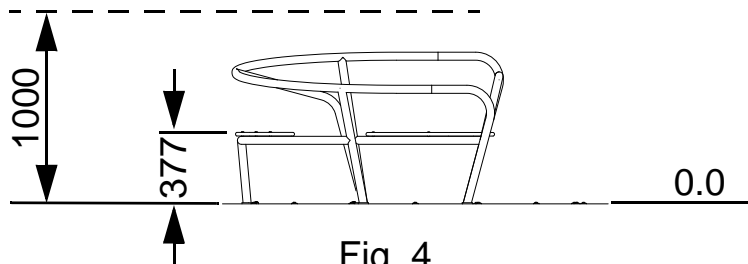

Fig. 4

101/144

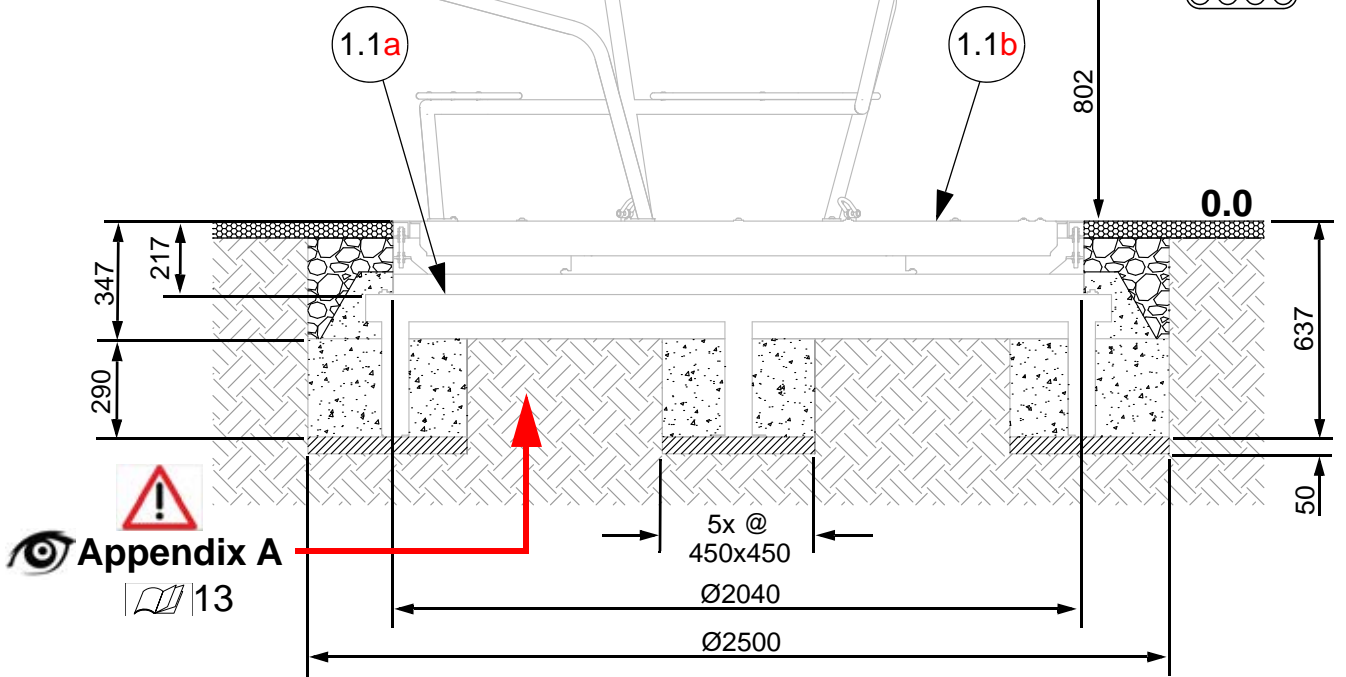
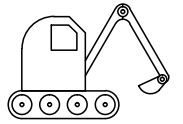

Fig. 5

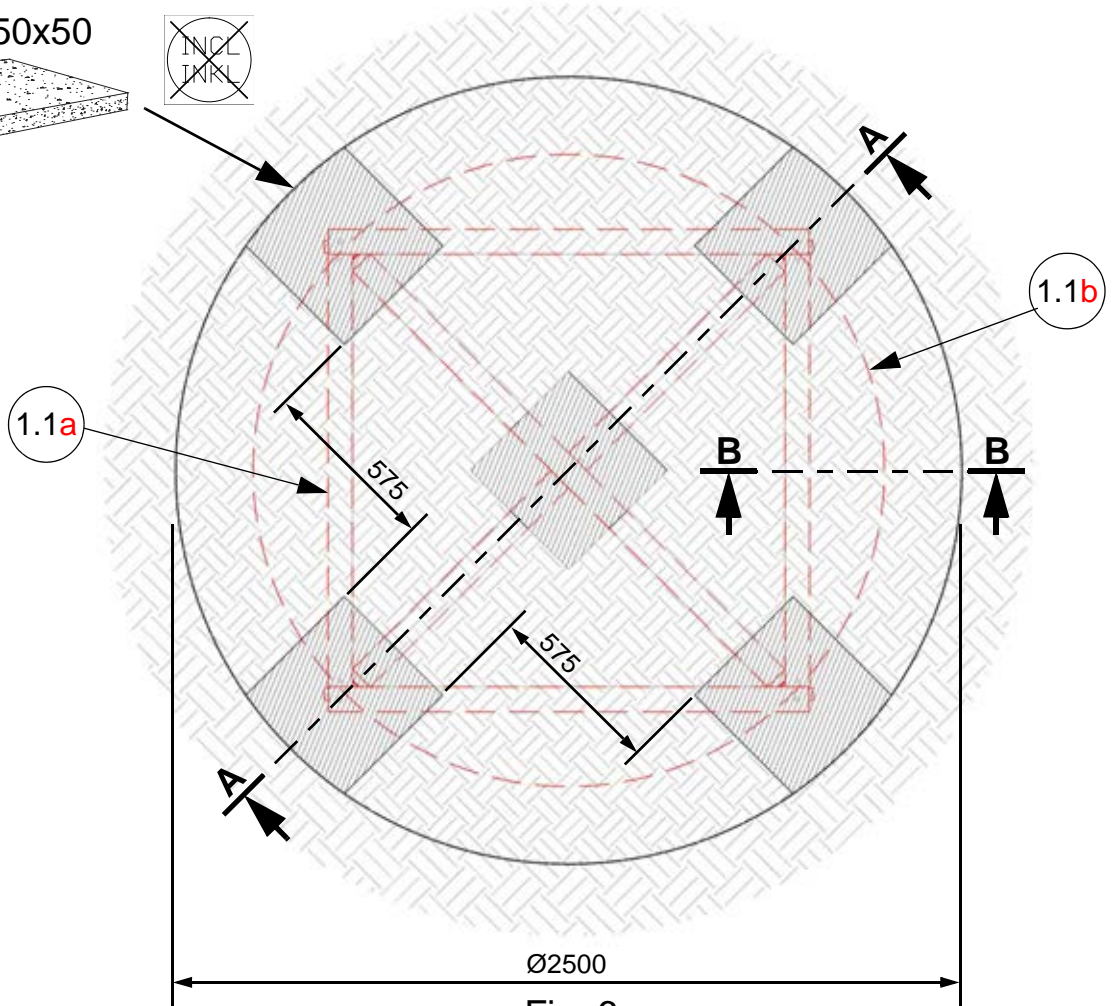
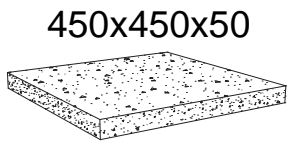
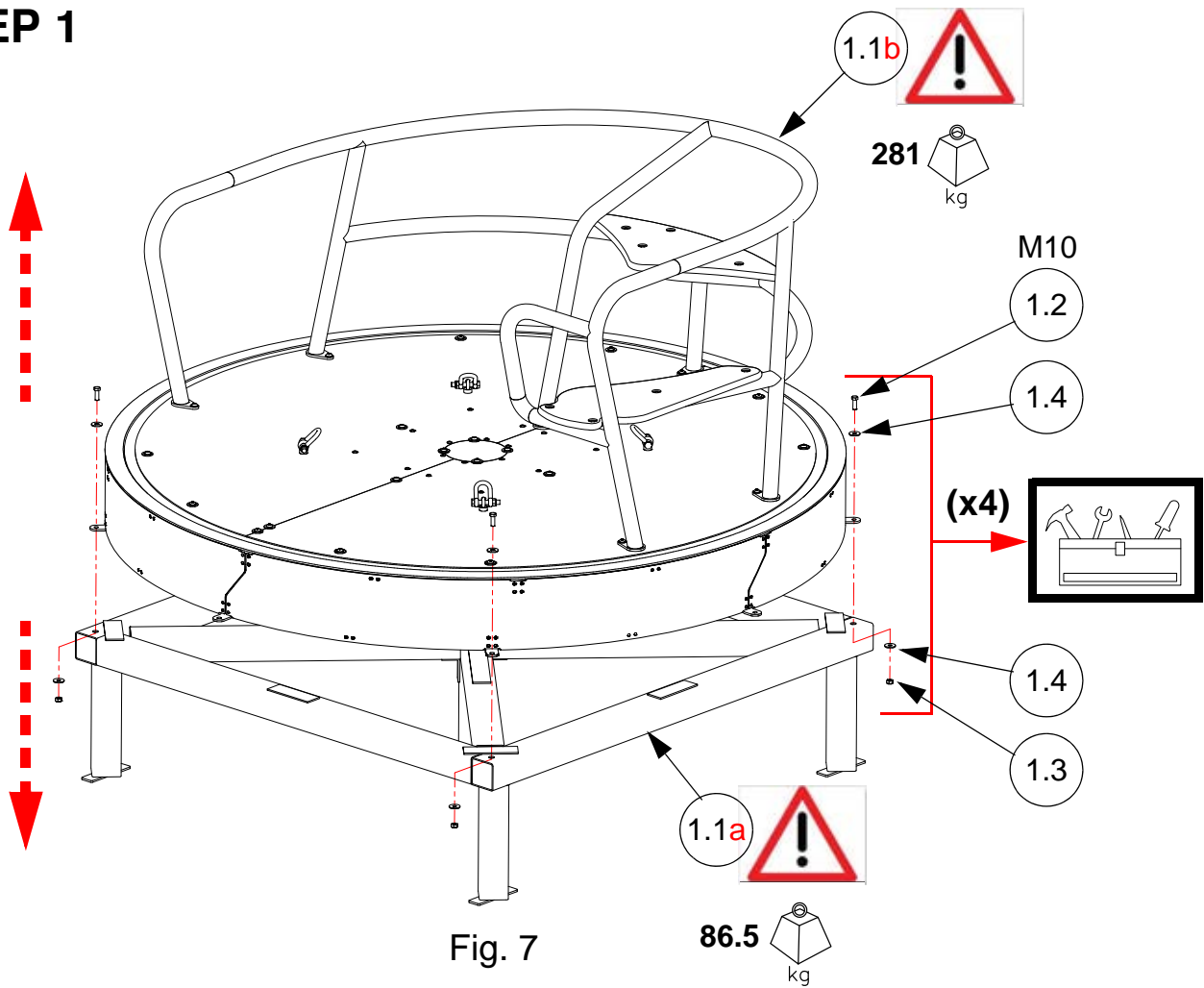
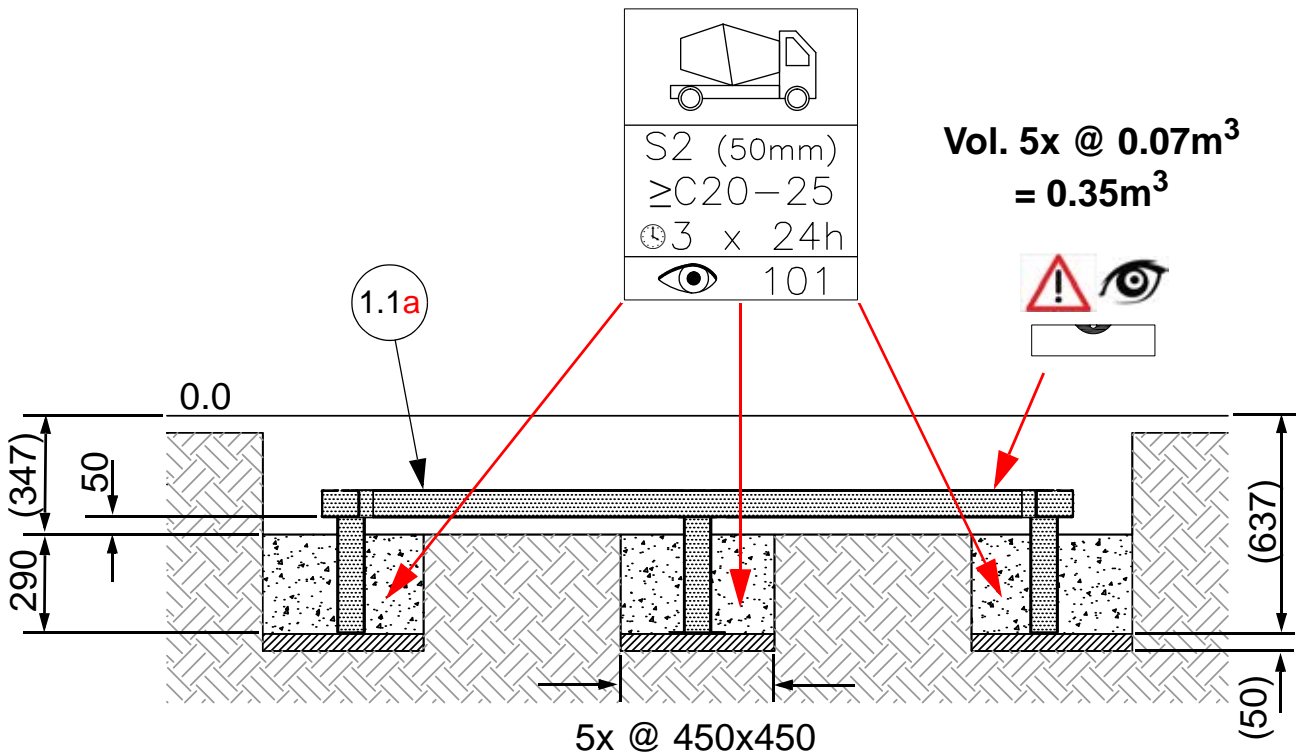

Fig. 6

STEP 1



STEP 2



STEP 3a

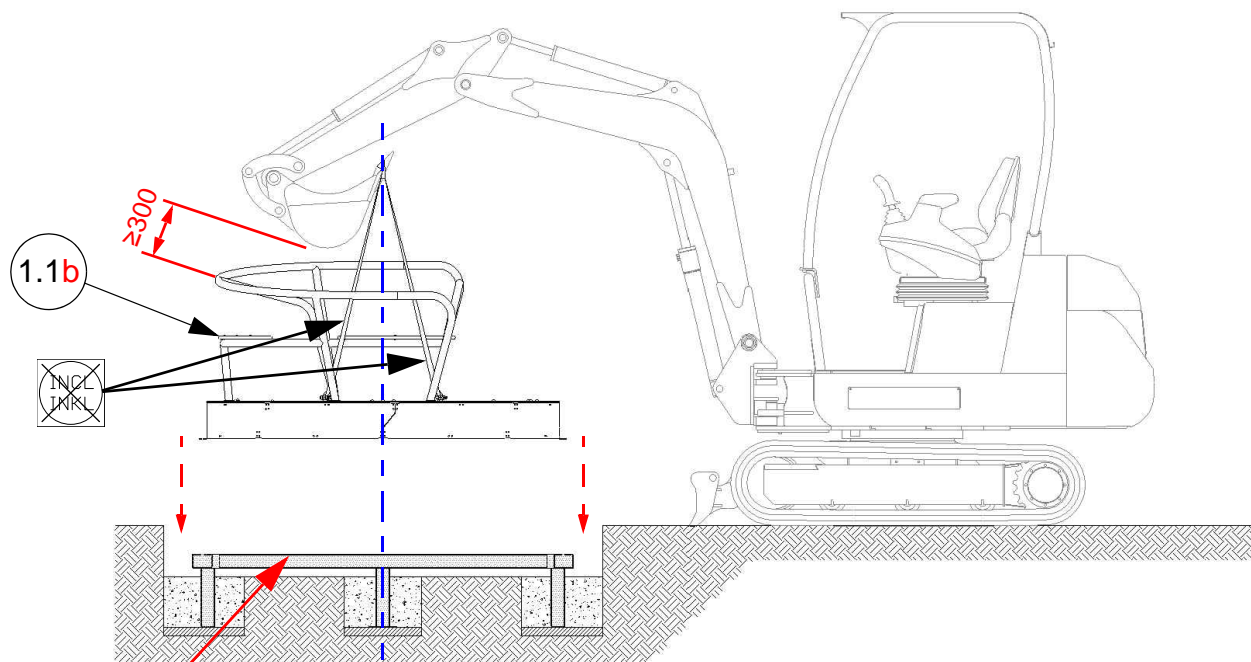

Fig. 9



STEP 3b

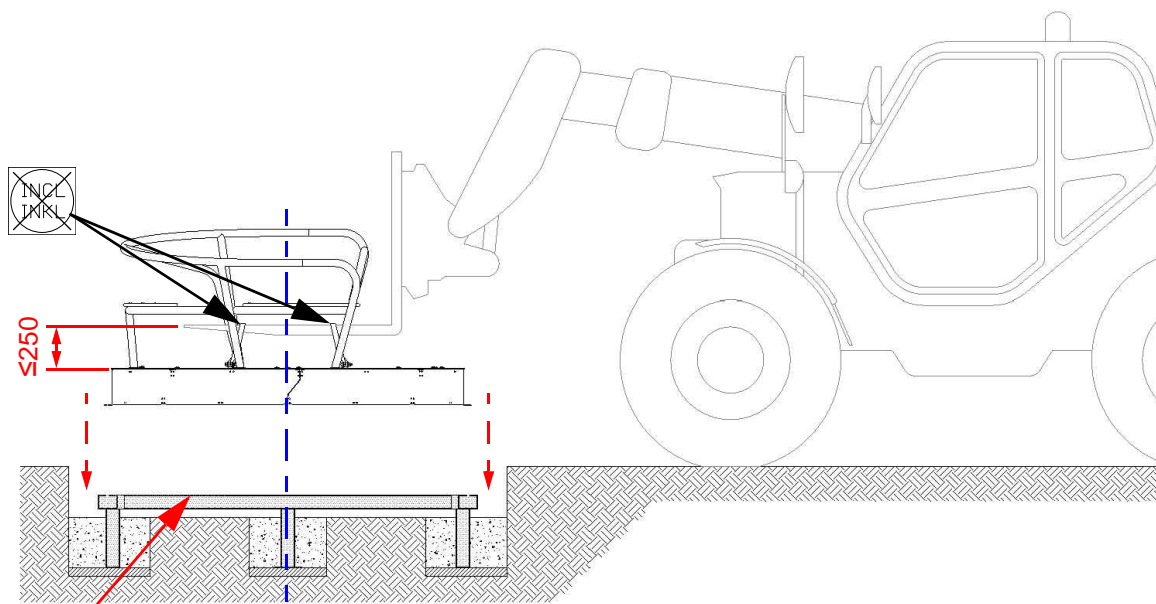

Fig. 10



STEP 4

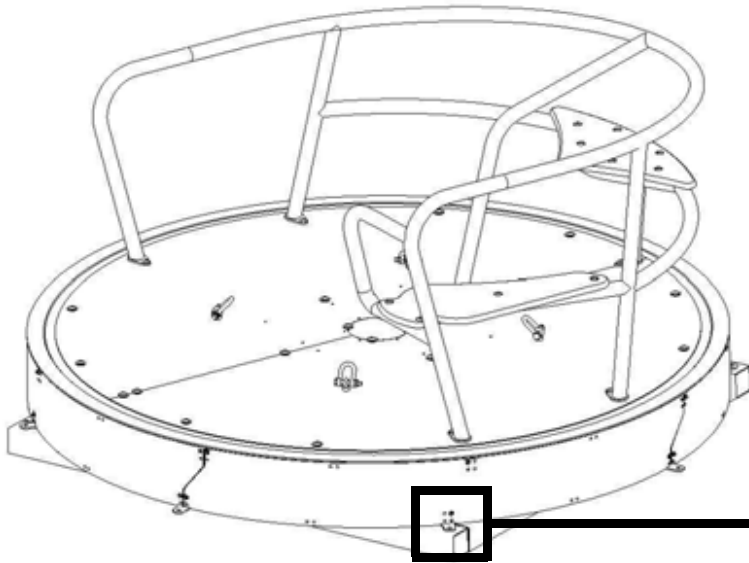

Fig. 11

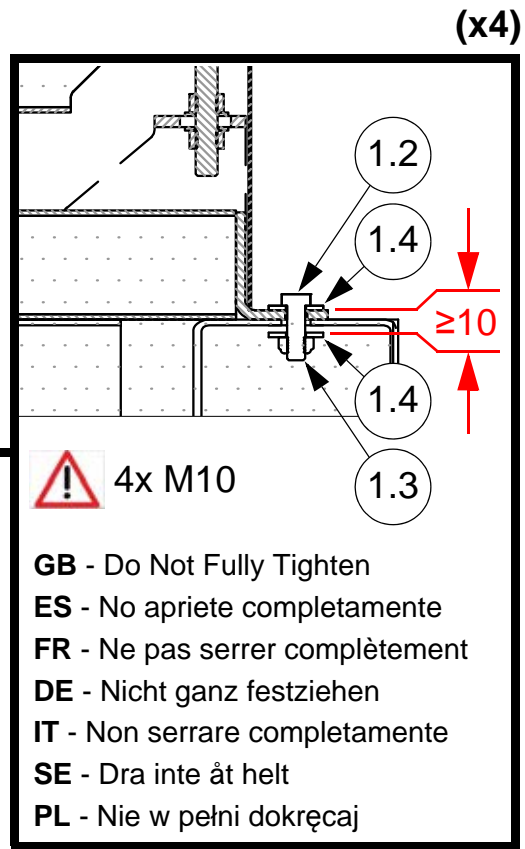
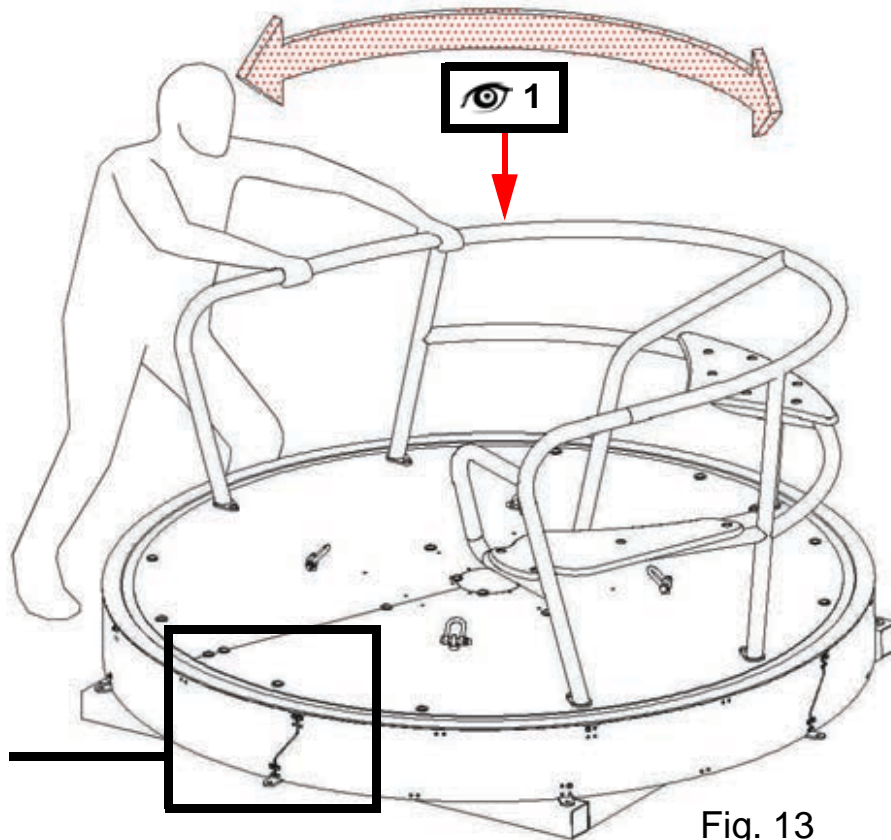

Fig. 12

STEP 5a



STEP 5b
 10

Fig. 13

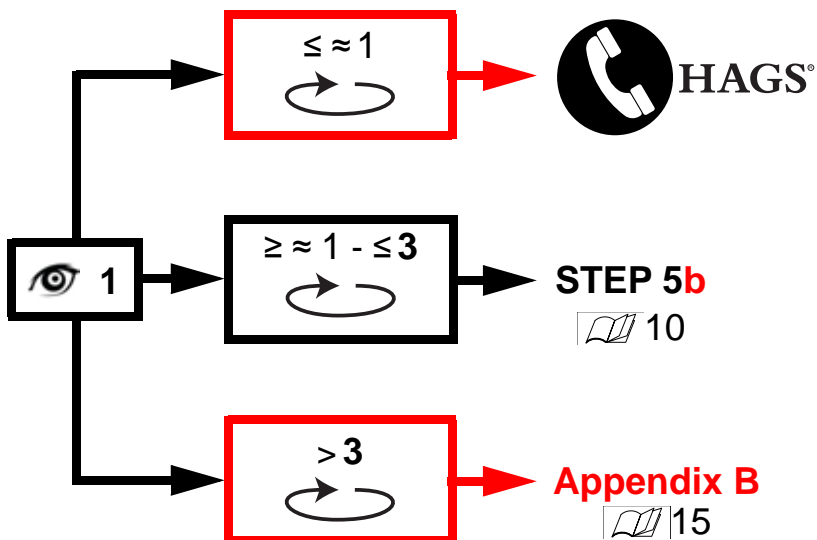

STEP 5b

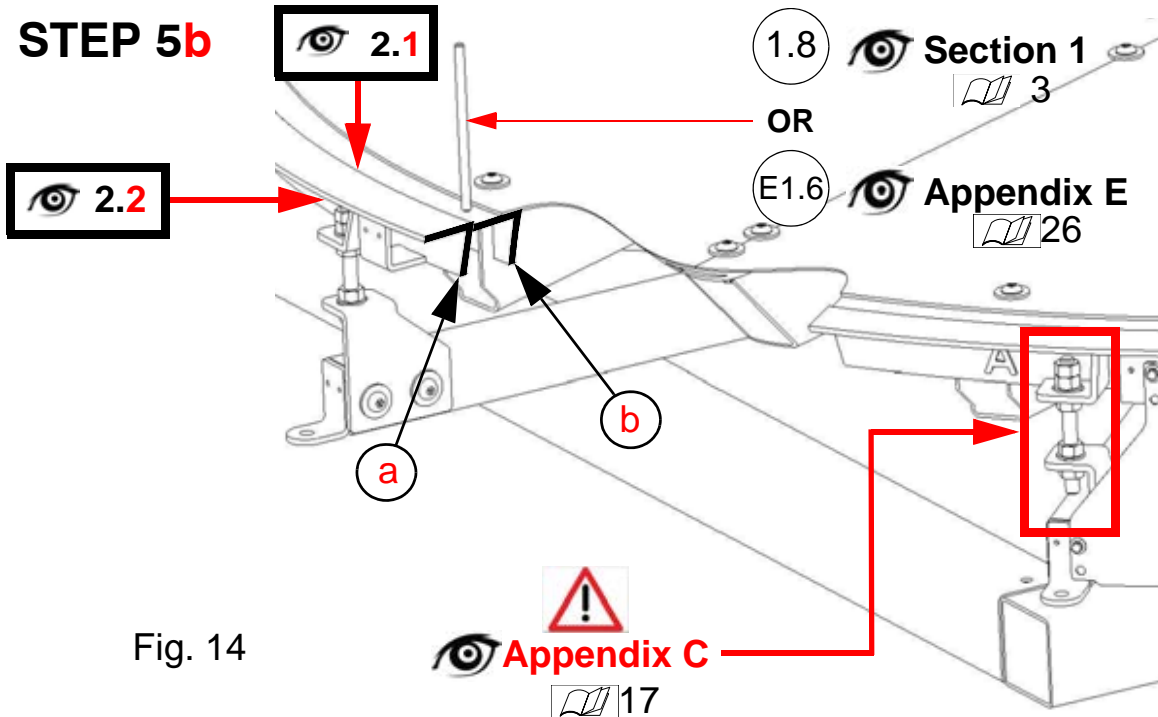
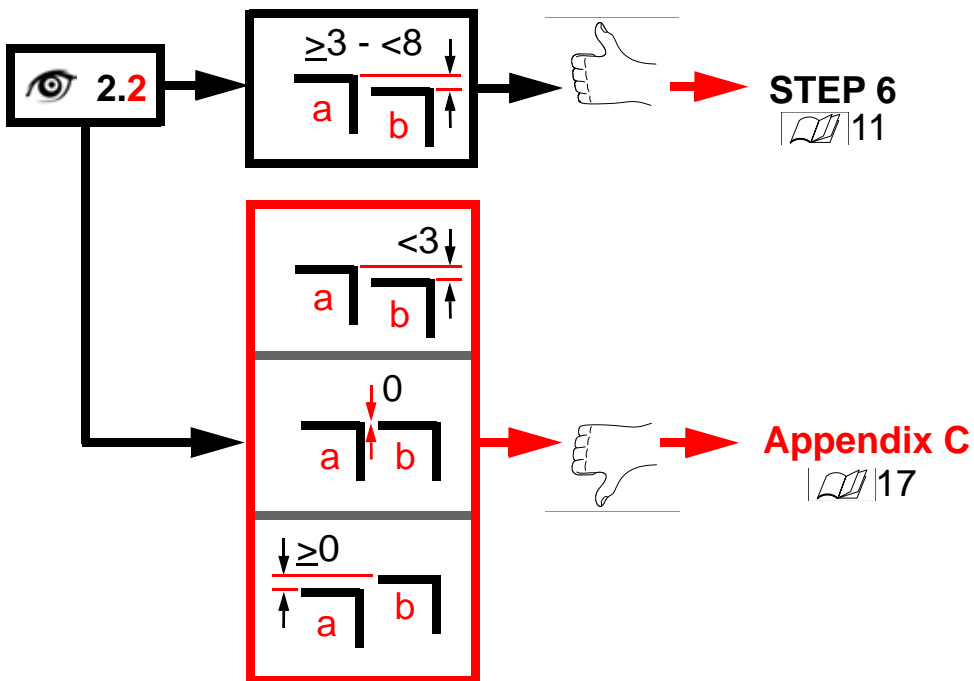
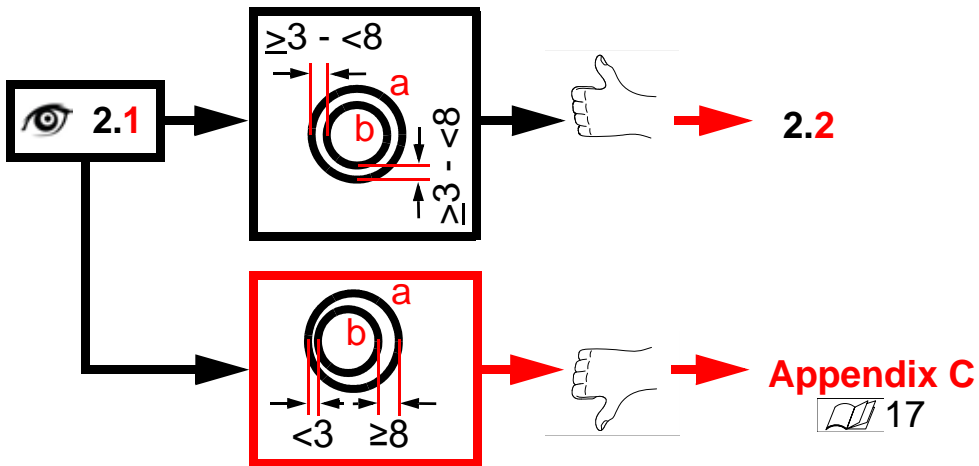
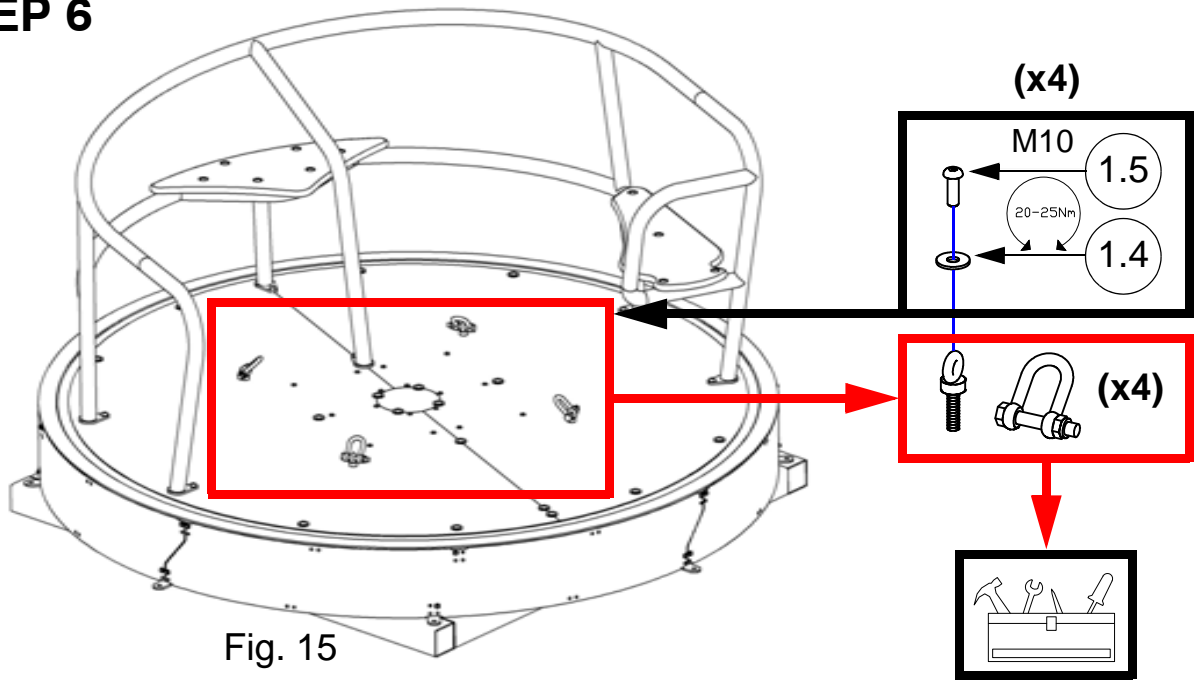

Fig. 14



STEP 6



STEP 7

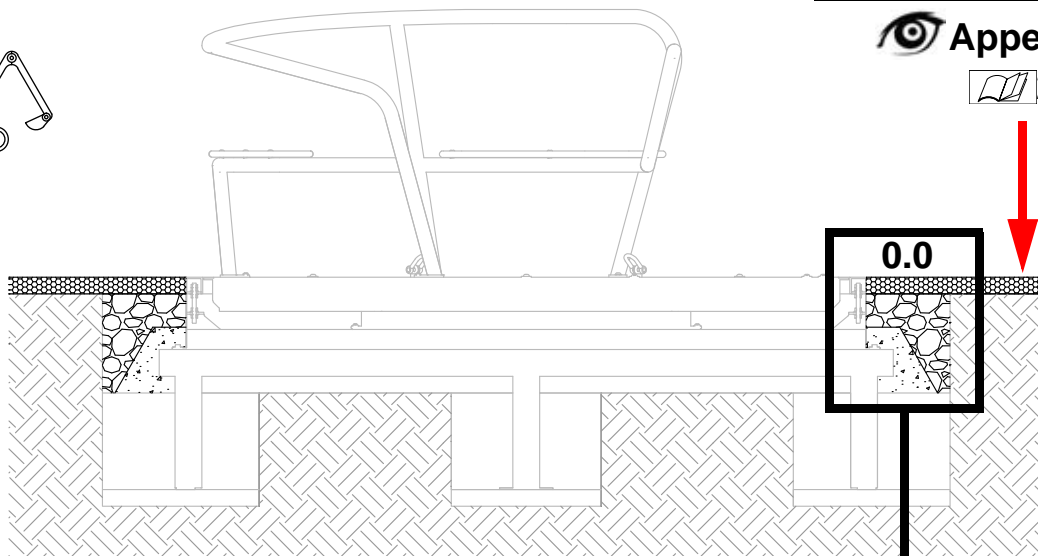
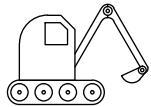

S2 (50mm)
≥C20-25
⊕3 x 24h
101

Vol. = 0.25m³

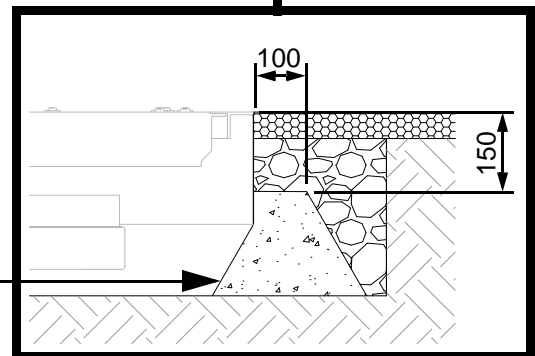

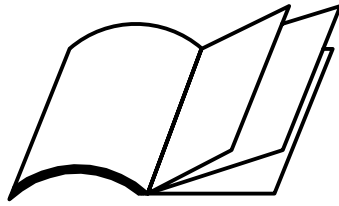

Appendix A:

STEP 1a

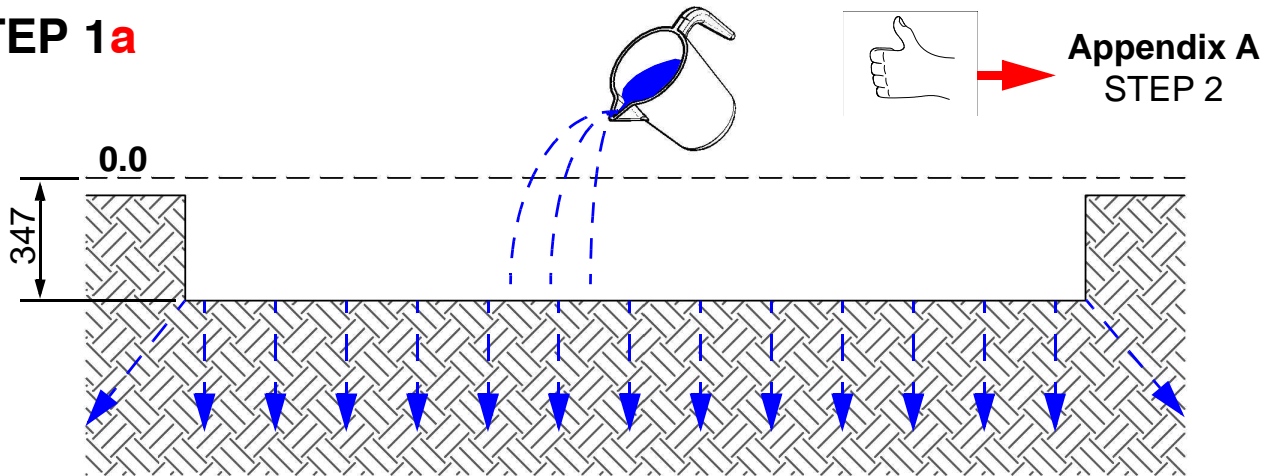

Fig. 1

STEP 1b

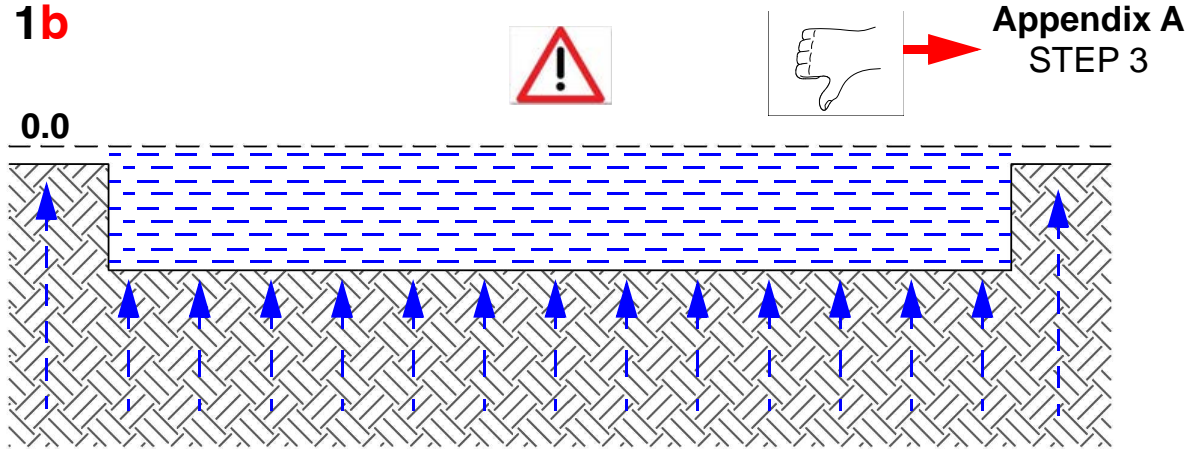

Fig. 2

STEP 2

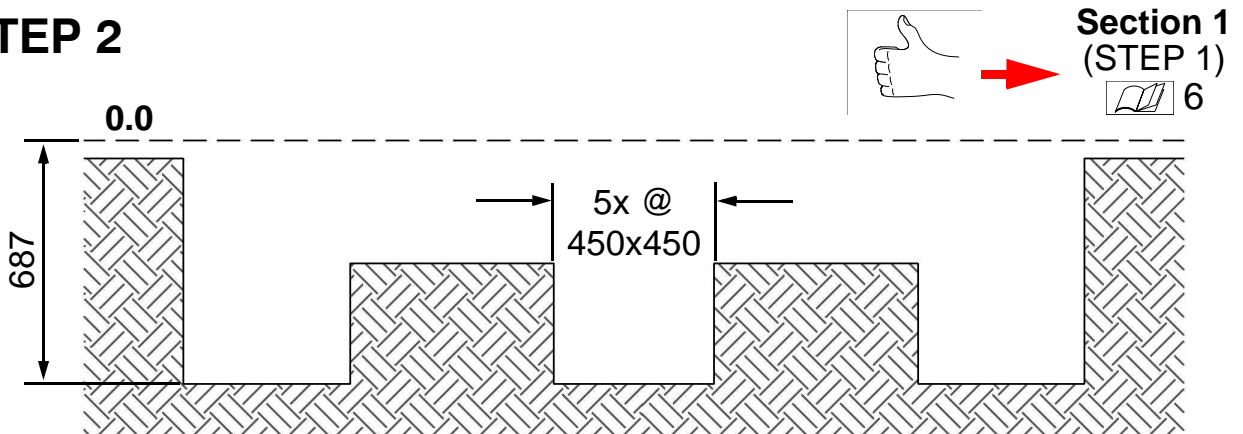
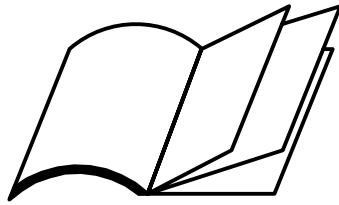

Fig. 3

STEP 3

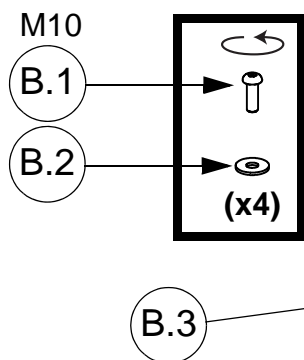

Fig. 4



Appendix B:

STEP 1



REF.	QTY.
B.1	4
B.2	4
B.3	1
B.4	3(a, b, c)

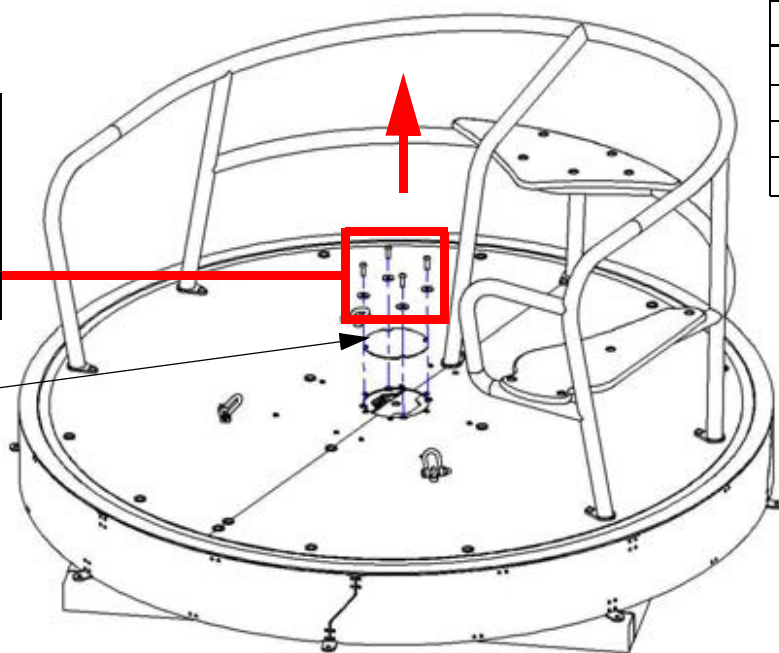
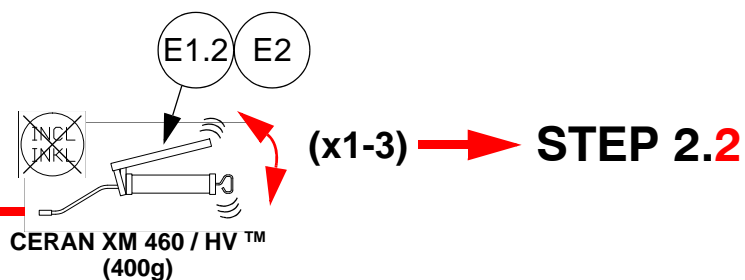
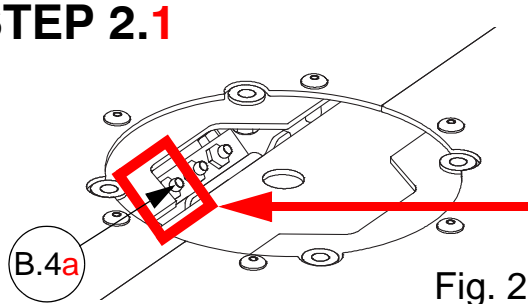
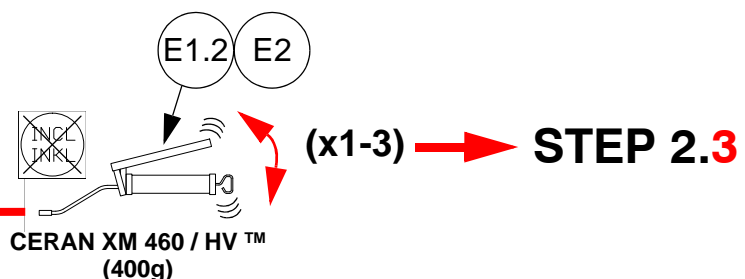
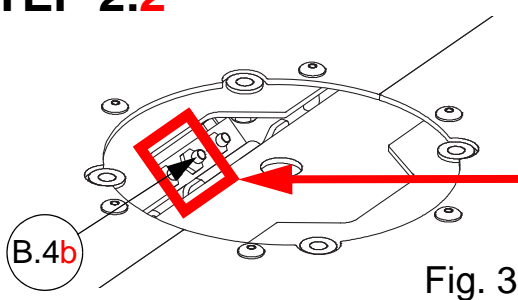

Fig. 1

STEP 2.1



STEP 2.2



STEP 2.3

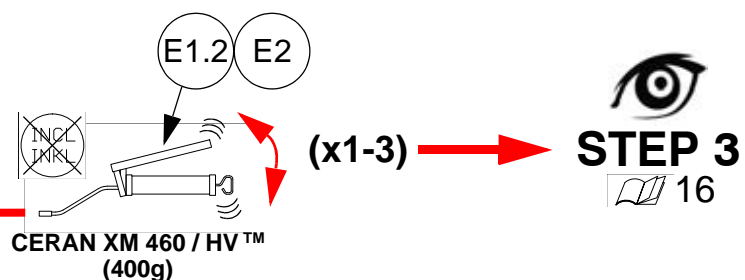
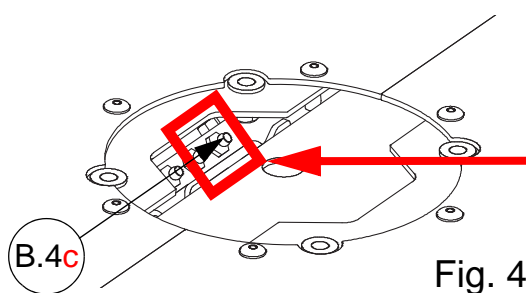

STEP 3

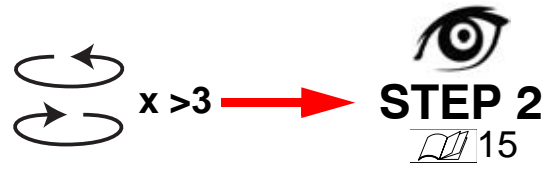
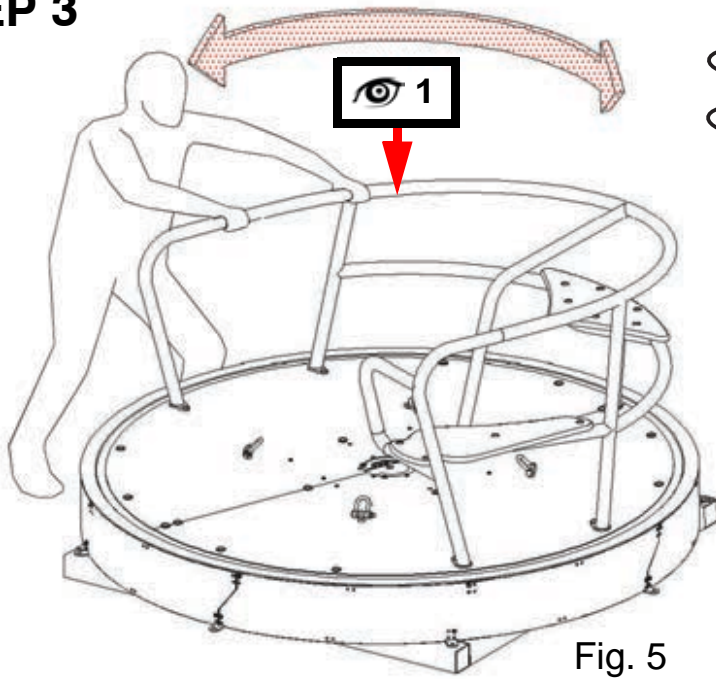
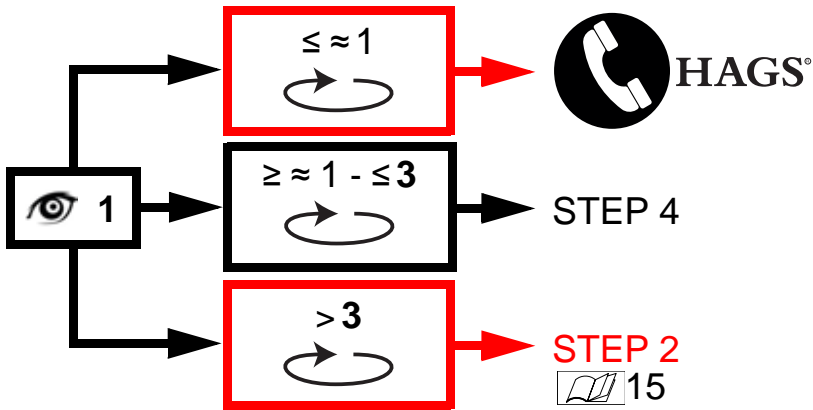

Fig. 5



STEP 4

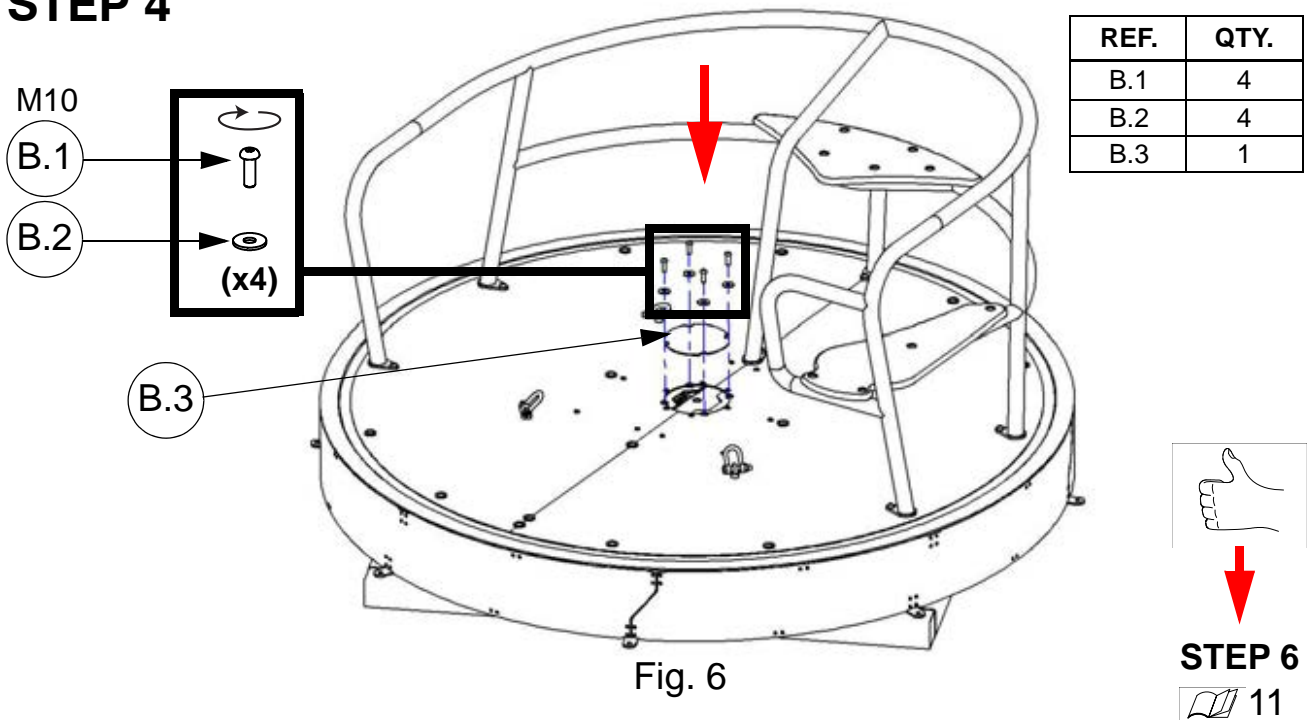

Fig. 6



STEP 6
 11

Appendix C:

STEP 1

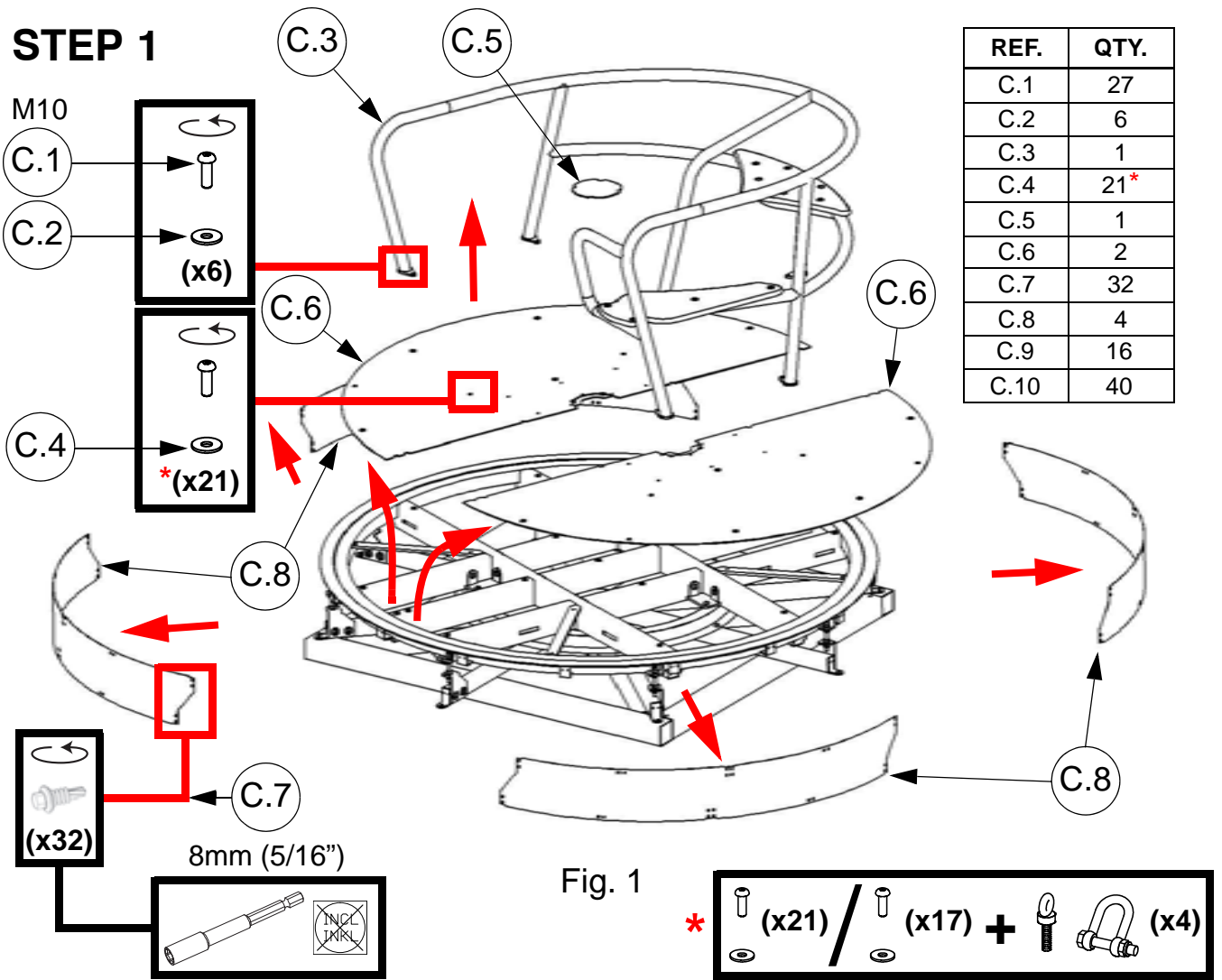

STEP 2

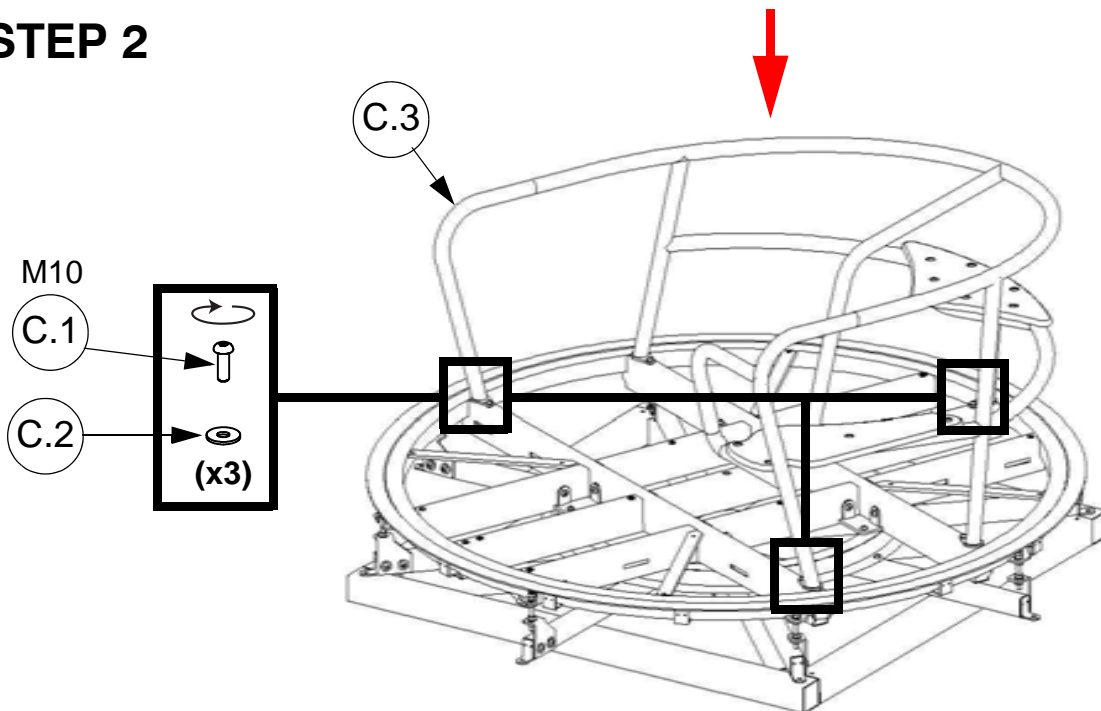

Fig. 2

STEP 3

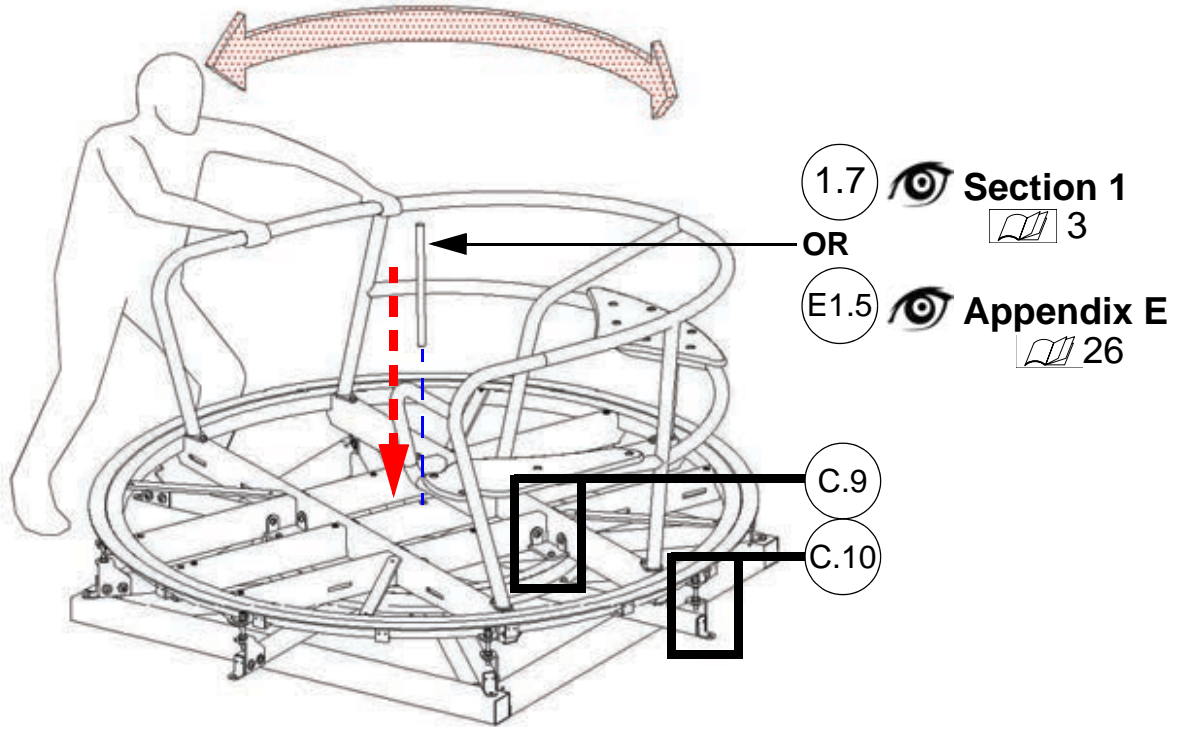

Fig. 3

STEP 4

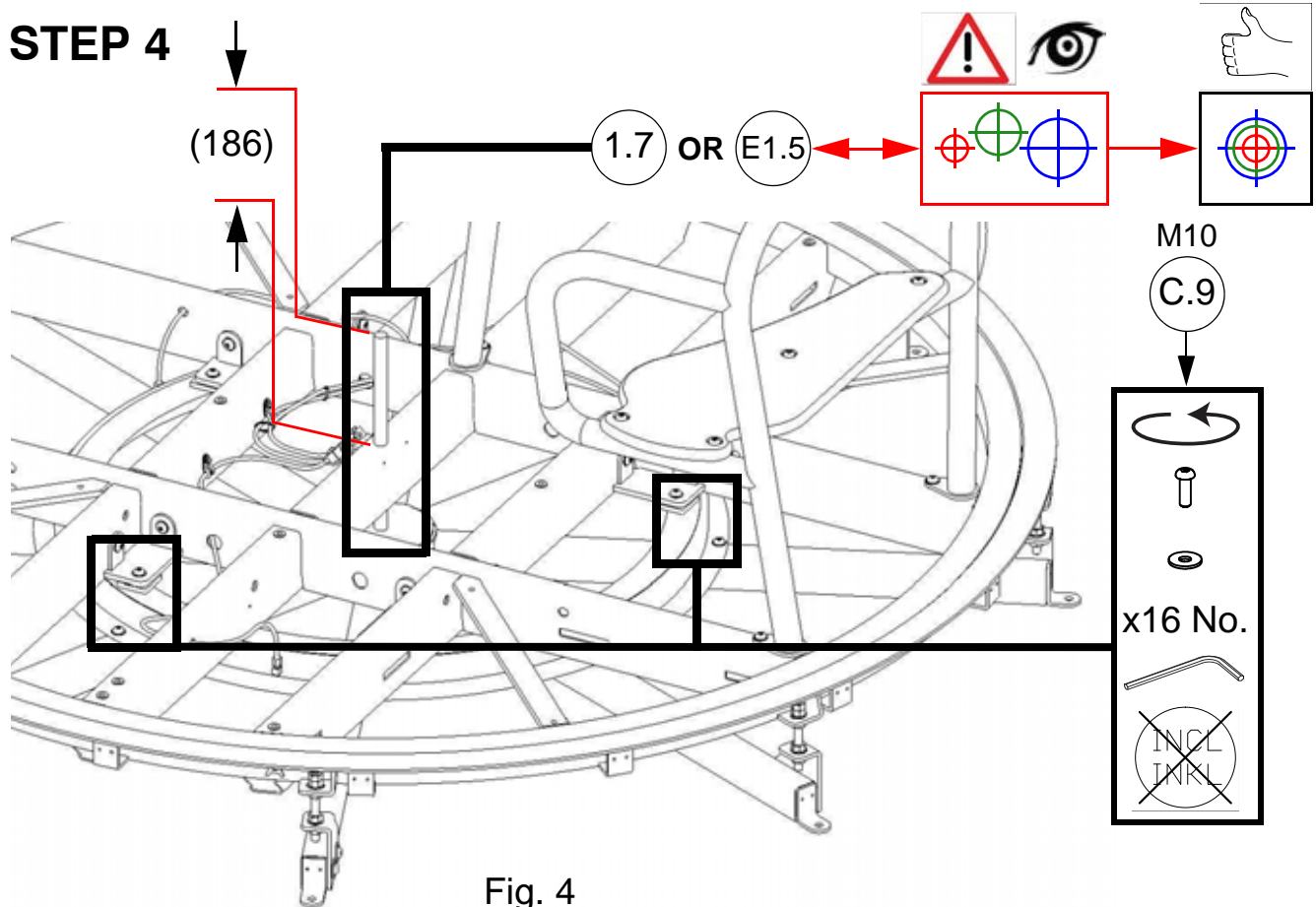
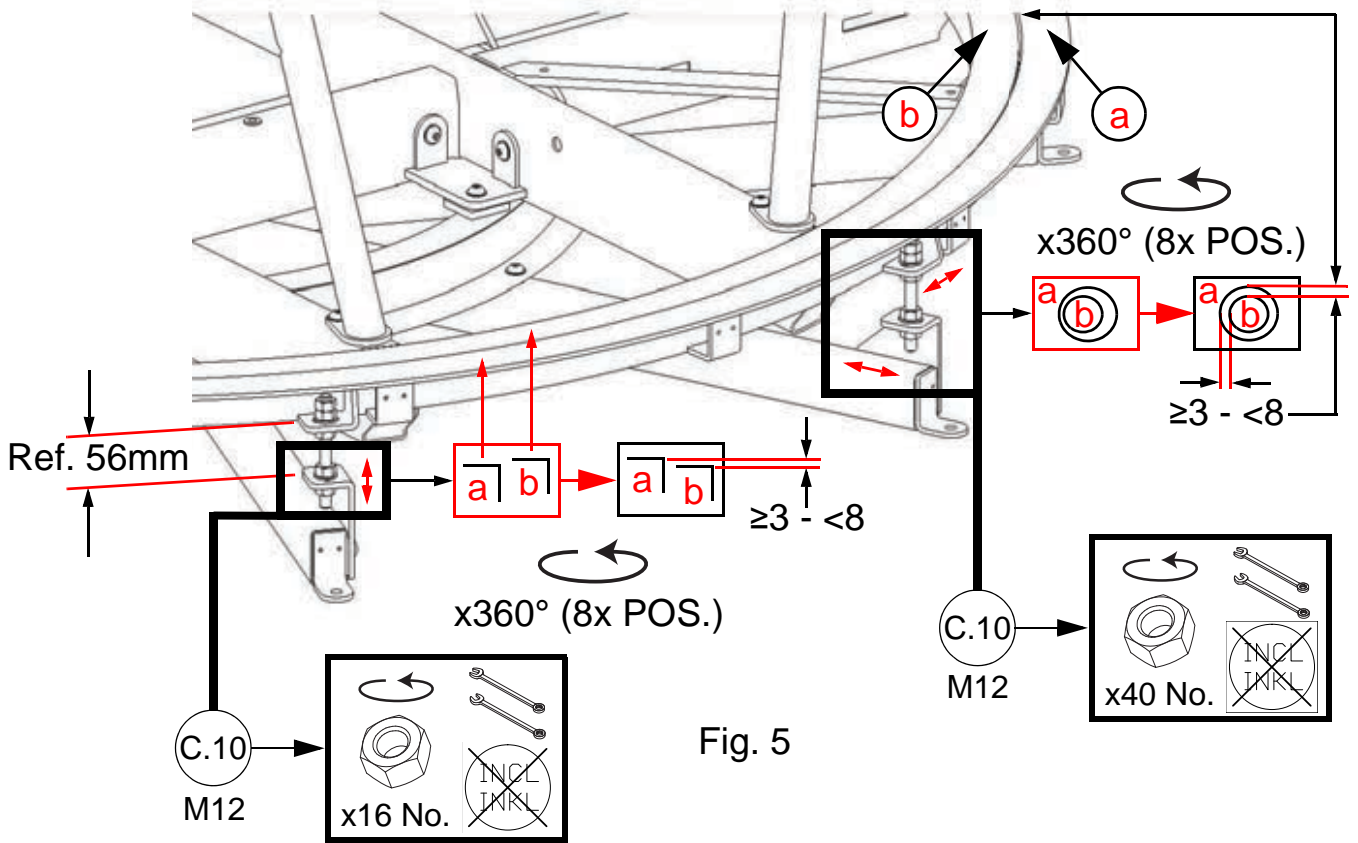
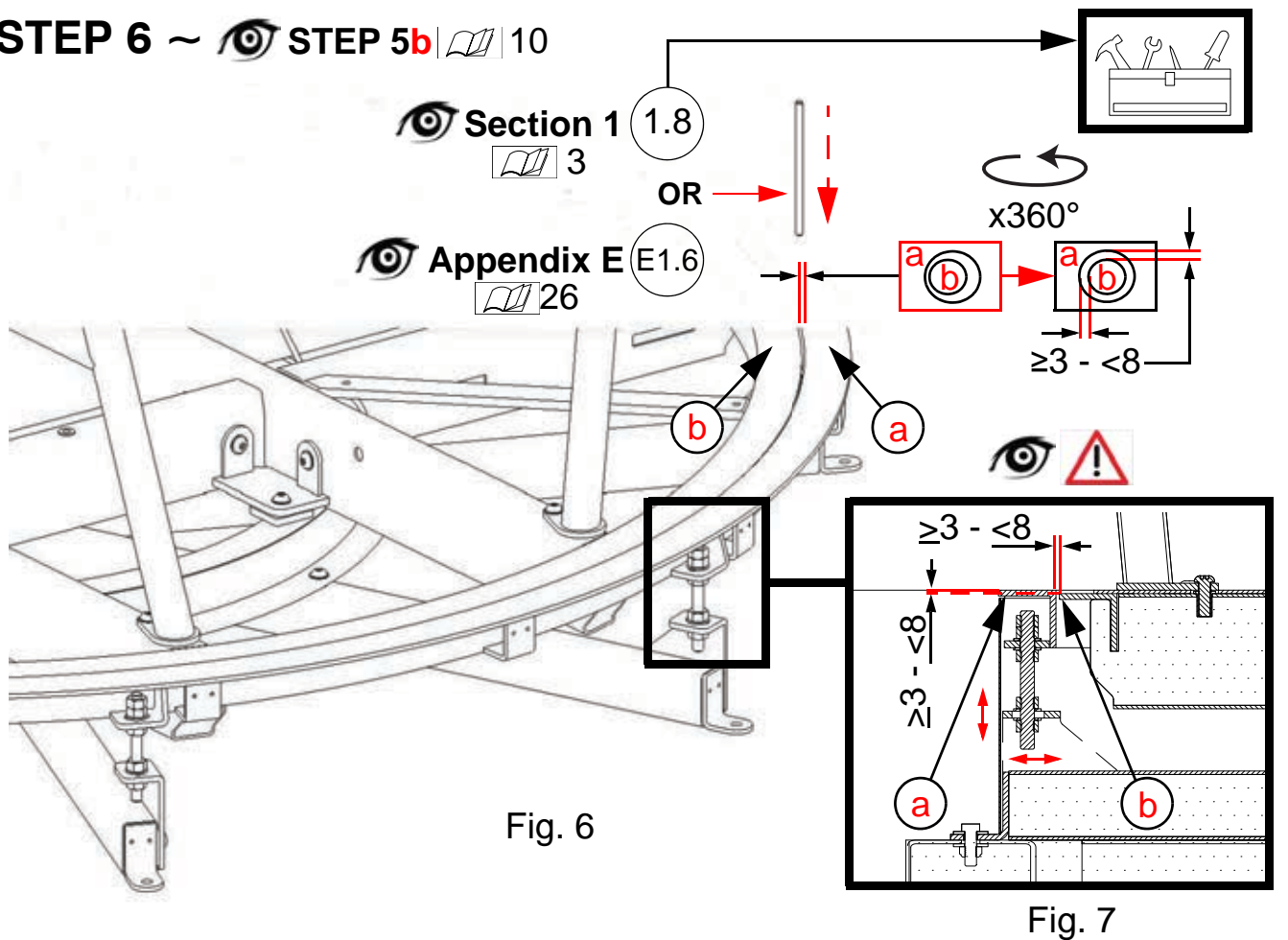

Fig. 4

STEP 5 ~ **STEP 5b** 10



STEP 6 ~ **STEP 5b** 10



STEP 7

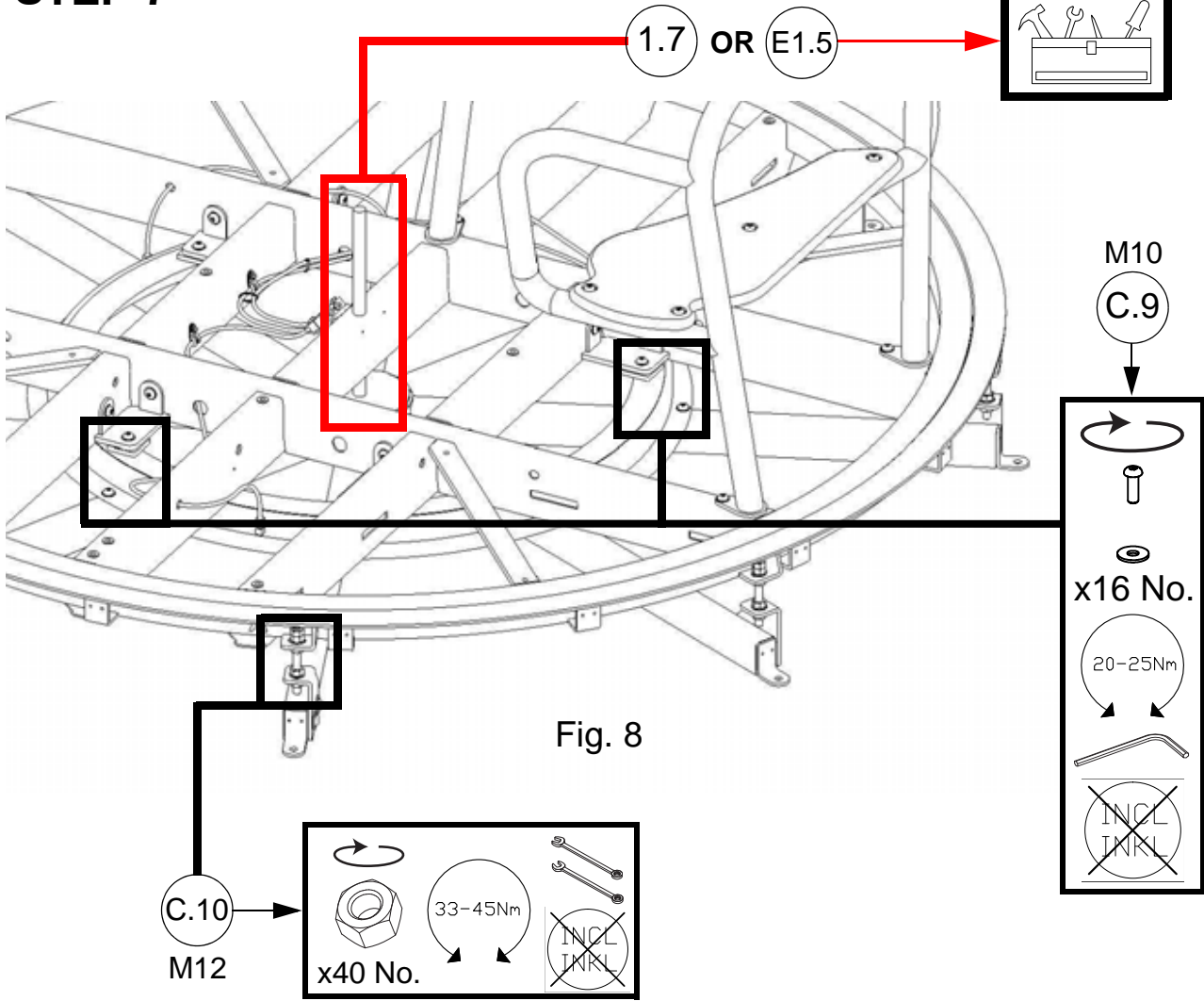

STEP 8

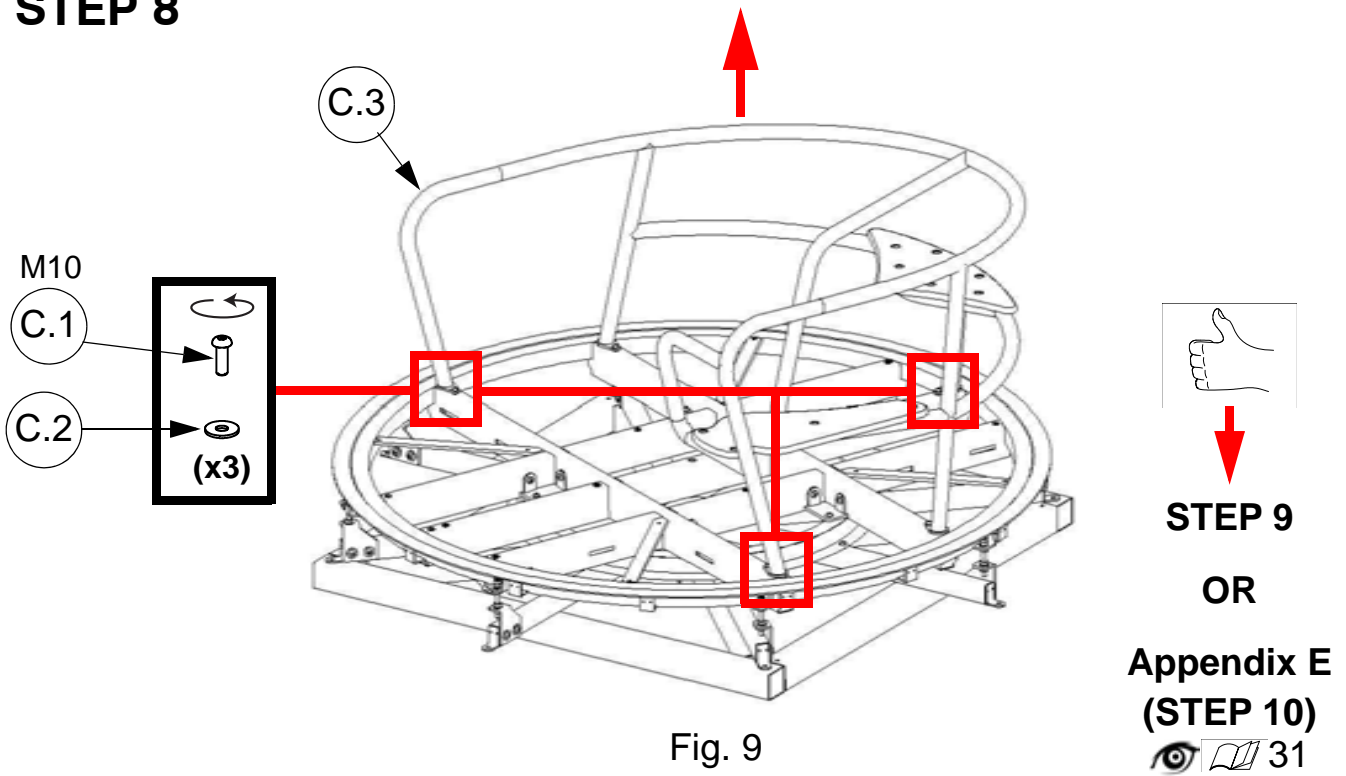

STEP 9

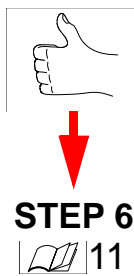
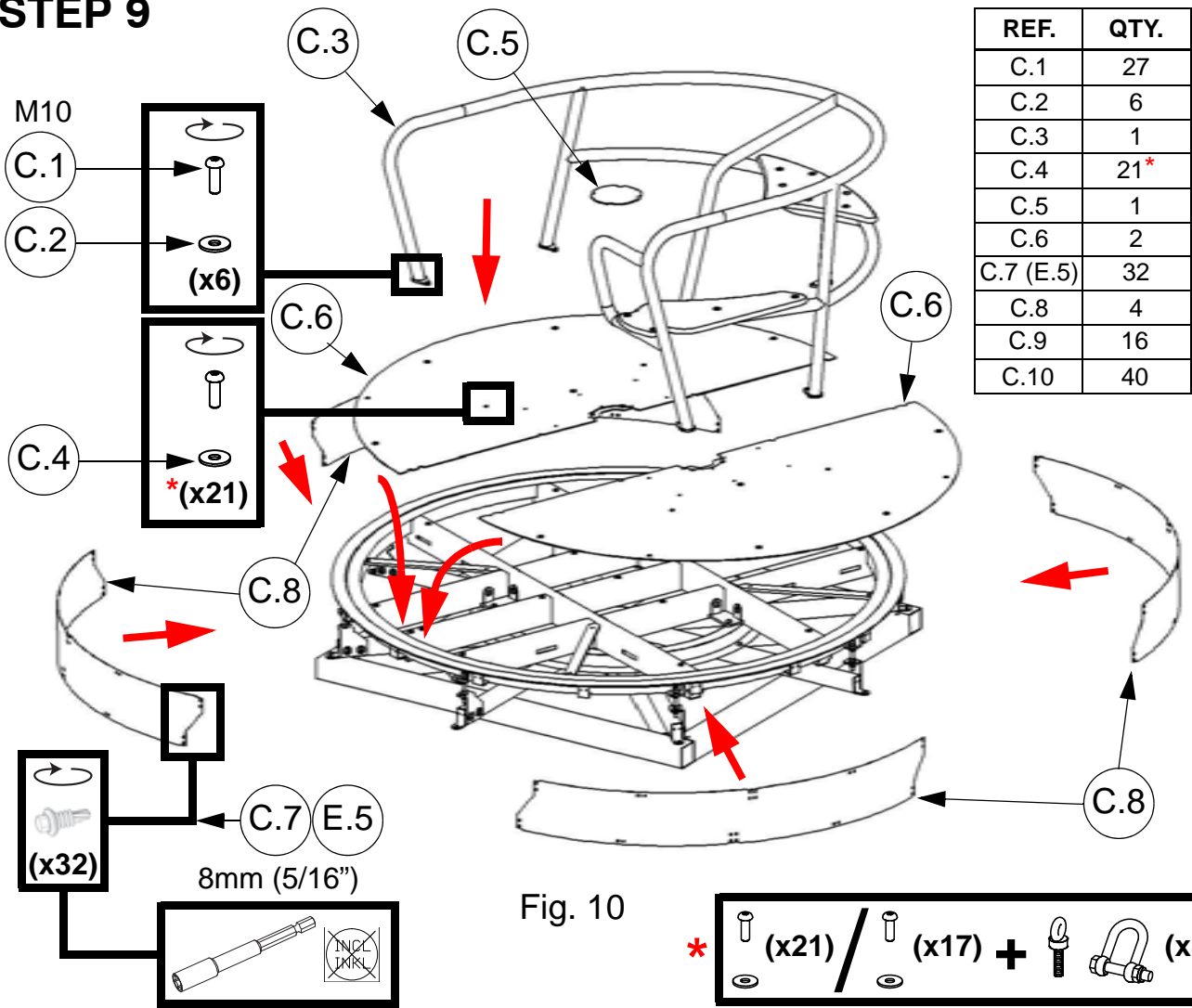

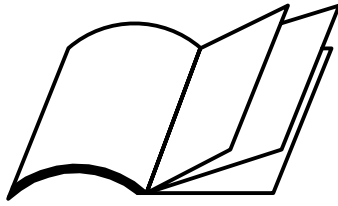

Appendix D:

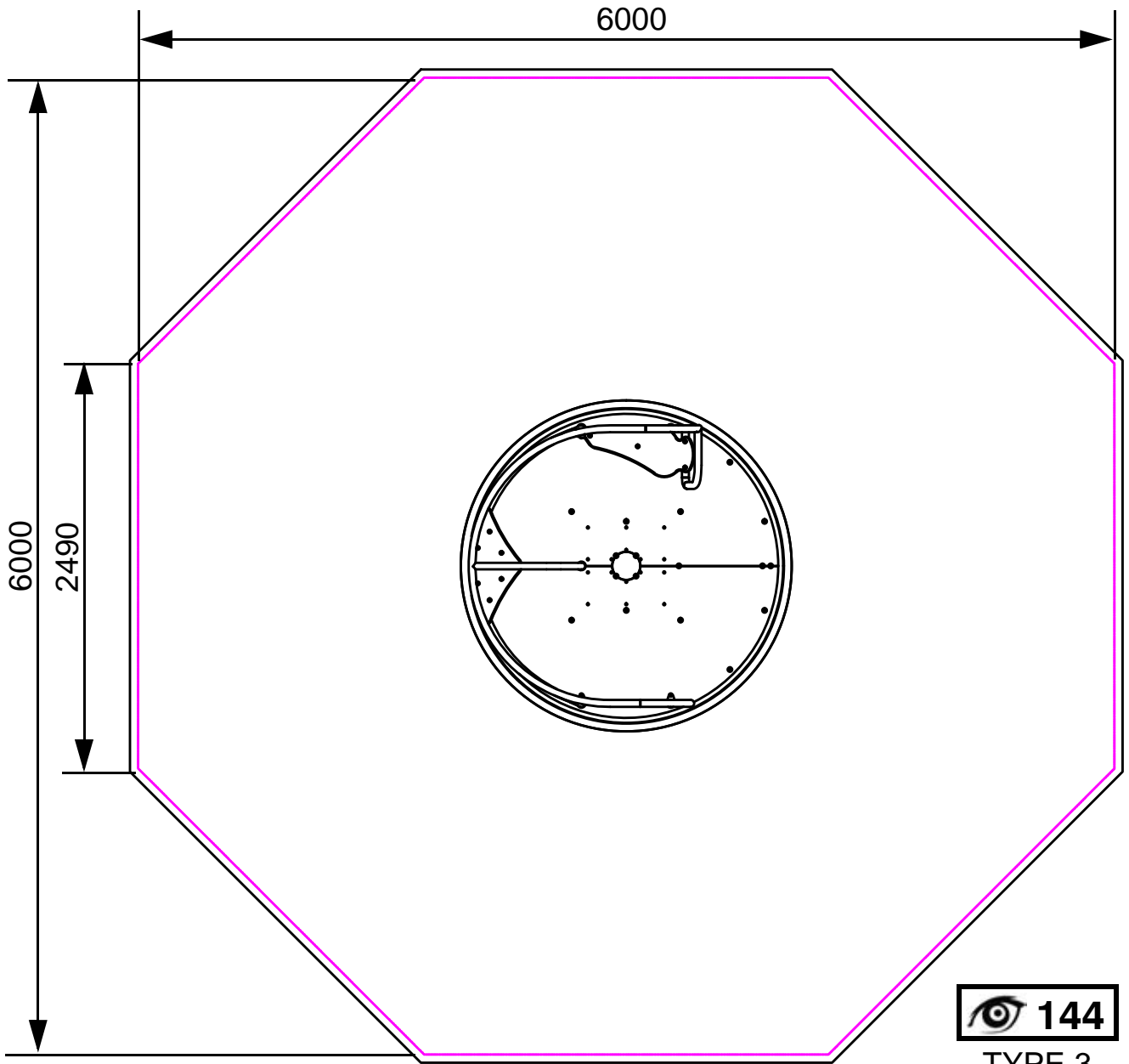



Fig. 1

 144

TYPE 3



STEP 7

 11

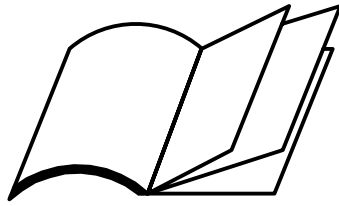

Appendix E:

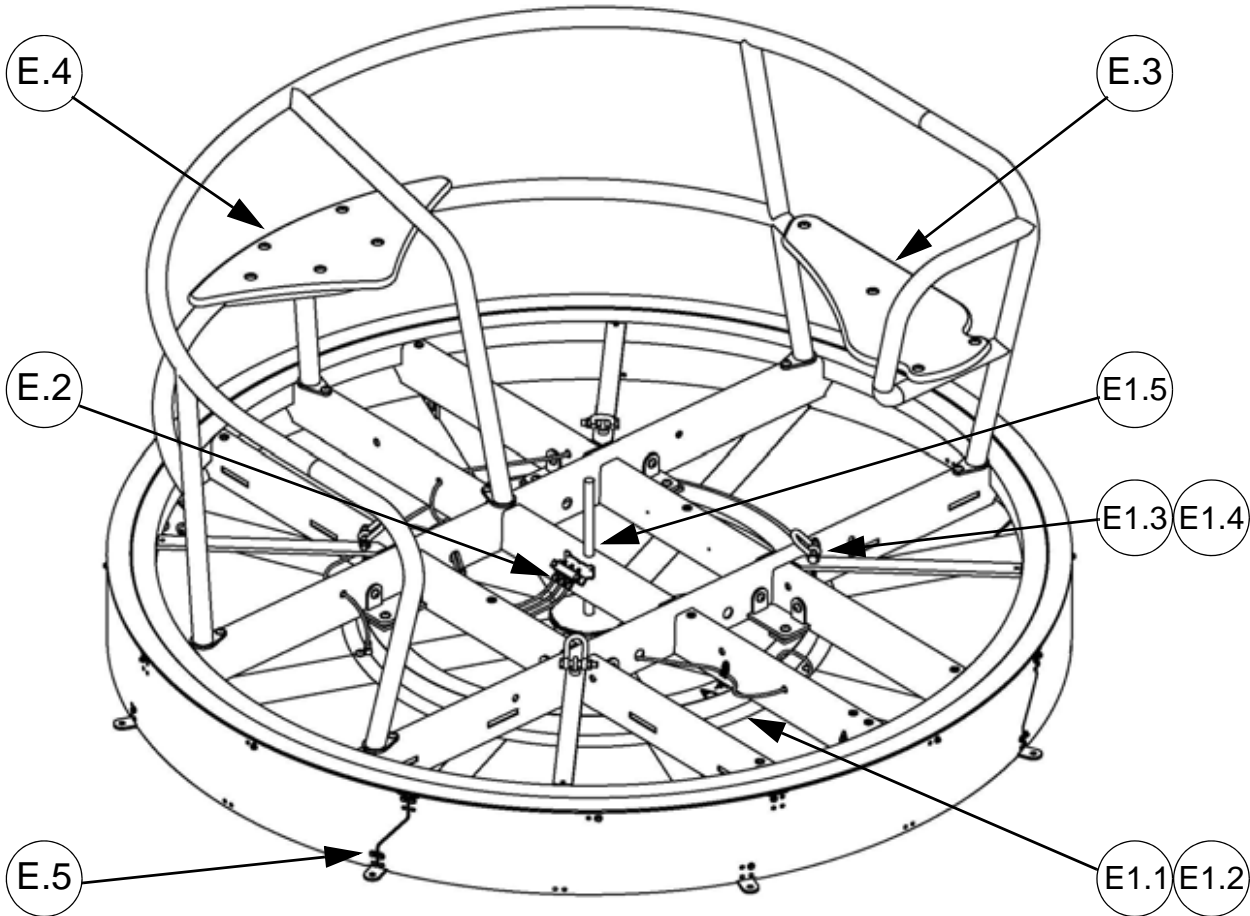

Fig. 1

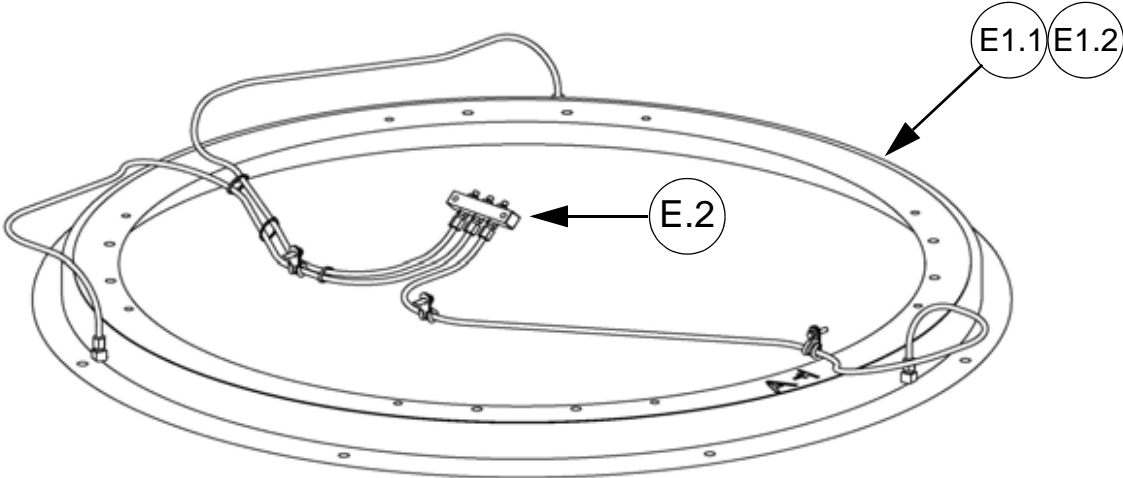

Fig. 2

ITEM	REF	71401010	QTY	kg
E1.1	71404029	<p>Ø1050 52 (8x Ø10.5) (8x M10)</p>	1	0.45
E1.2	71404021	<p>CERAN XM 460 / HV ~ 400g</p>	1	0.40
E1.3	15711010	<p>M10</p>	4	0.03
E1.4	109303		4	0.03
E1.5	419305	<p>Ø20 X 400</p> <p> 18 Appendix C (STEP 3)</p>	1	1.00
E1.6	71403008	<p>Ø8 X 150</p> <p> 19 Appendix C (STEP 6)</p>	1	0.06

ITEM	REF	71401001	QTY	kg
E.2	71404039	<p>1200</p>	1	0.50
E.3	71402001	<p>302 680</p>	1	0.10
E.4	71402002	<p>619 312</p>	1	0.10
E.5	71404045	<p>Ø5.5x32 8mm (5/16")</p>	32	0.01

STEP 1

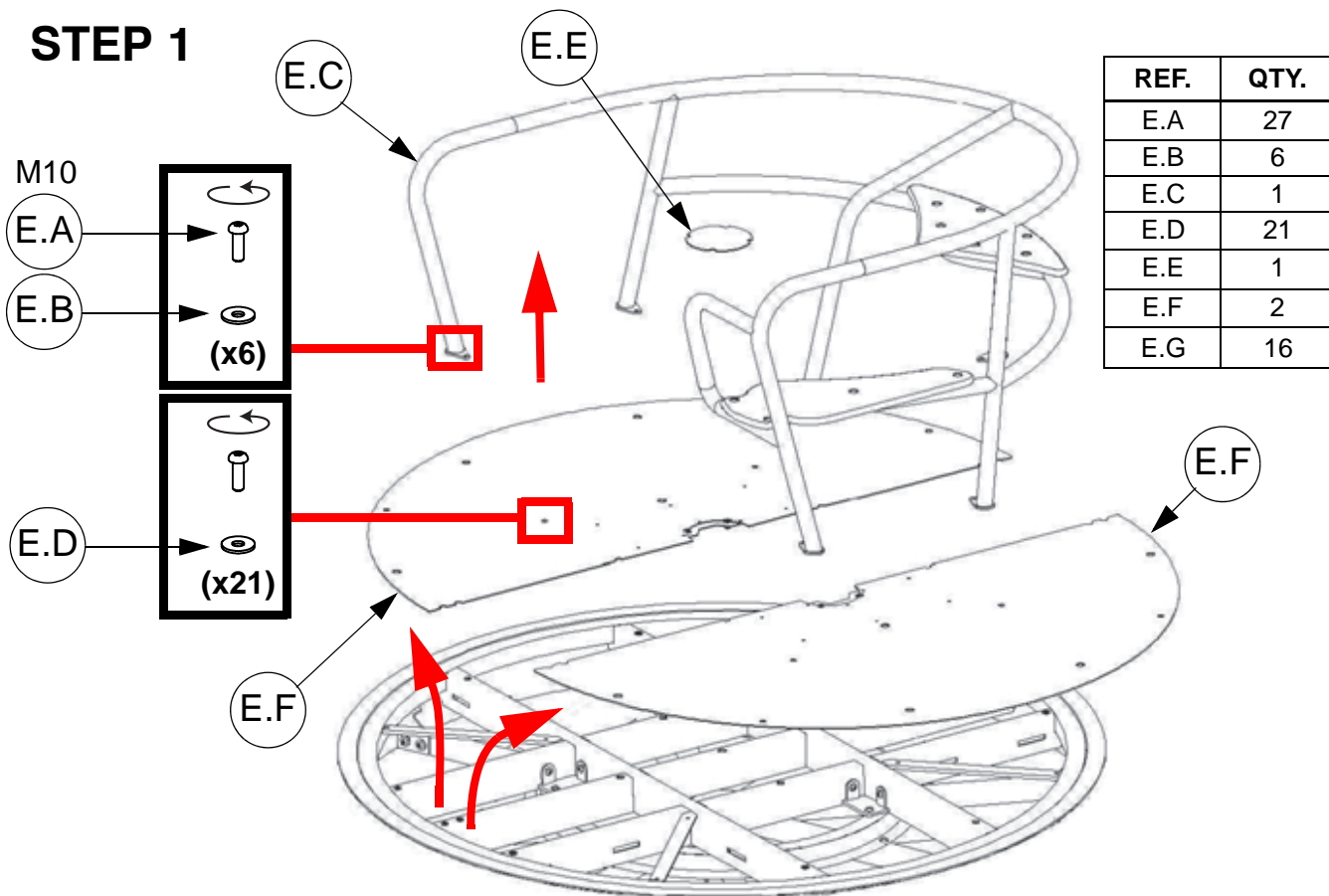

Fig. 3

STEP 2

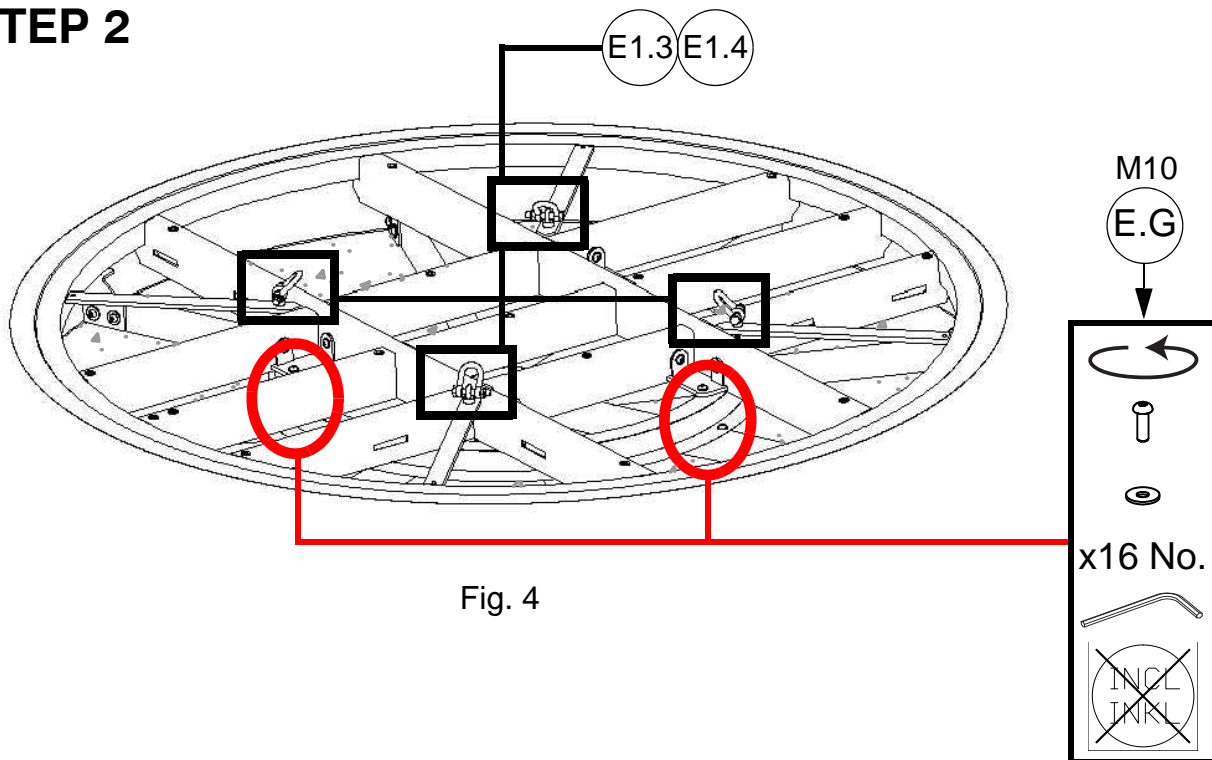
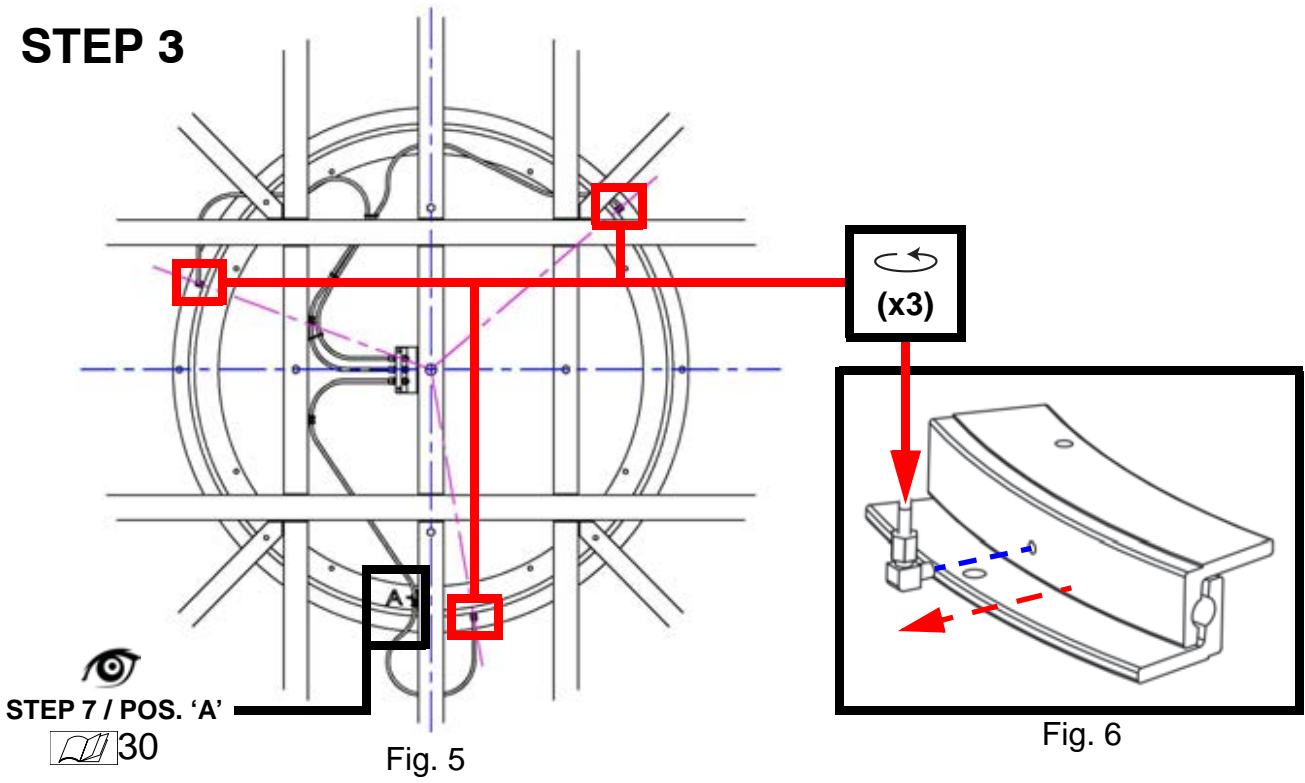
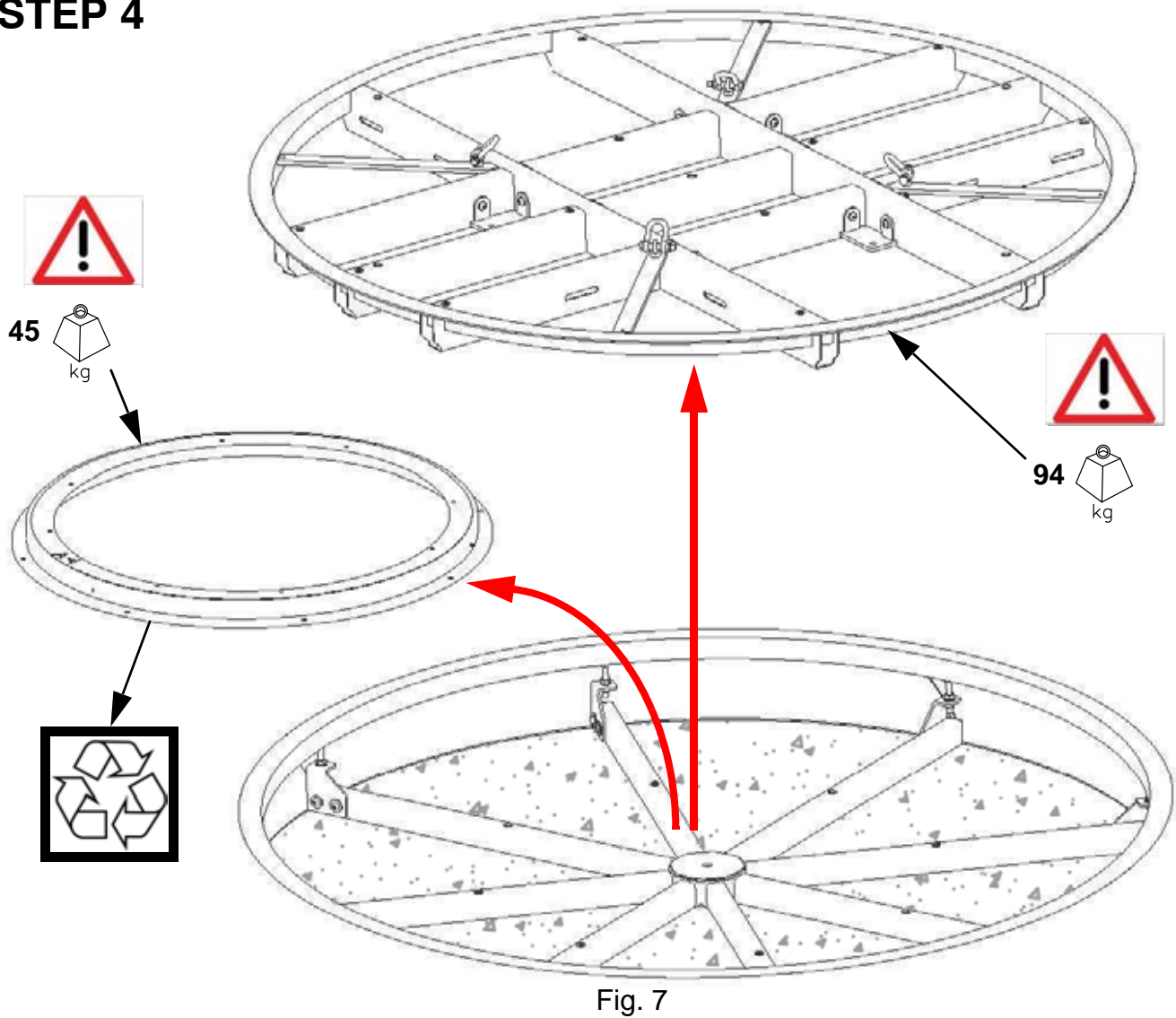

Fig. 4

STEP 3



STEP 4



STEP 5

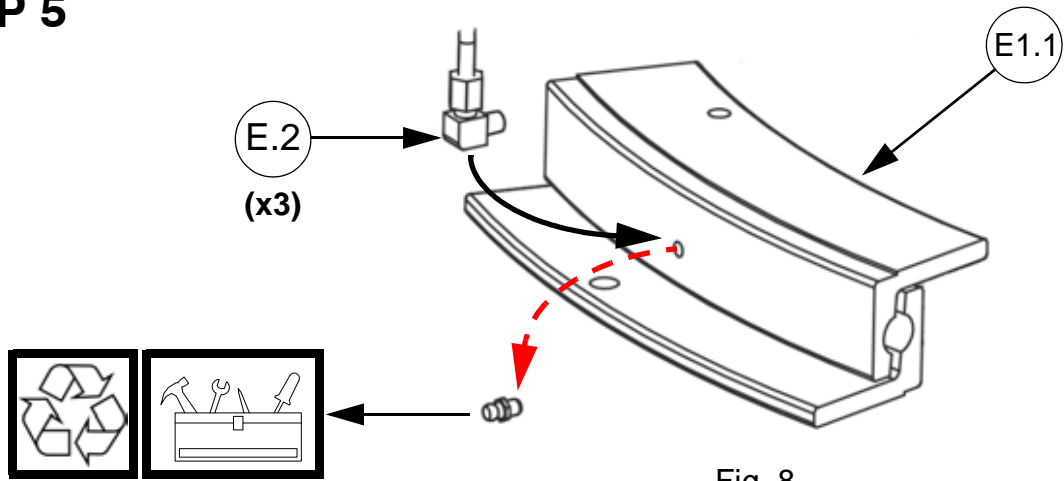

Fig. 8

STEP 6

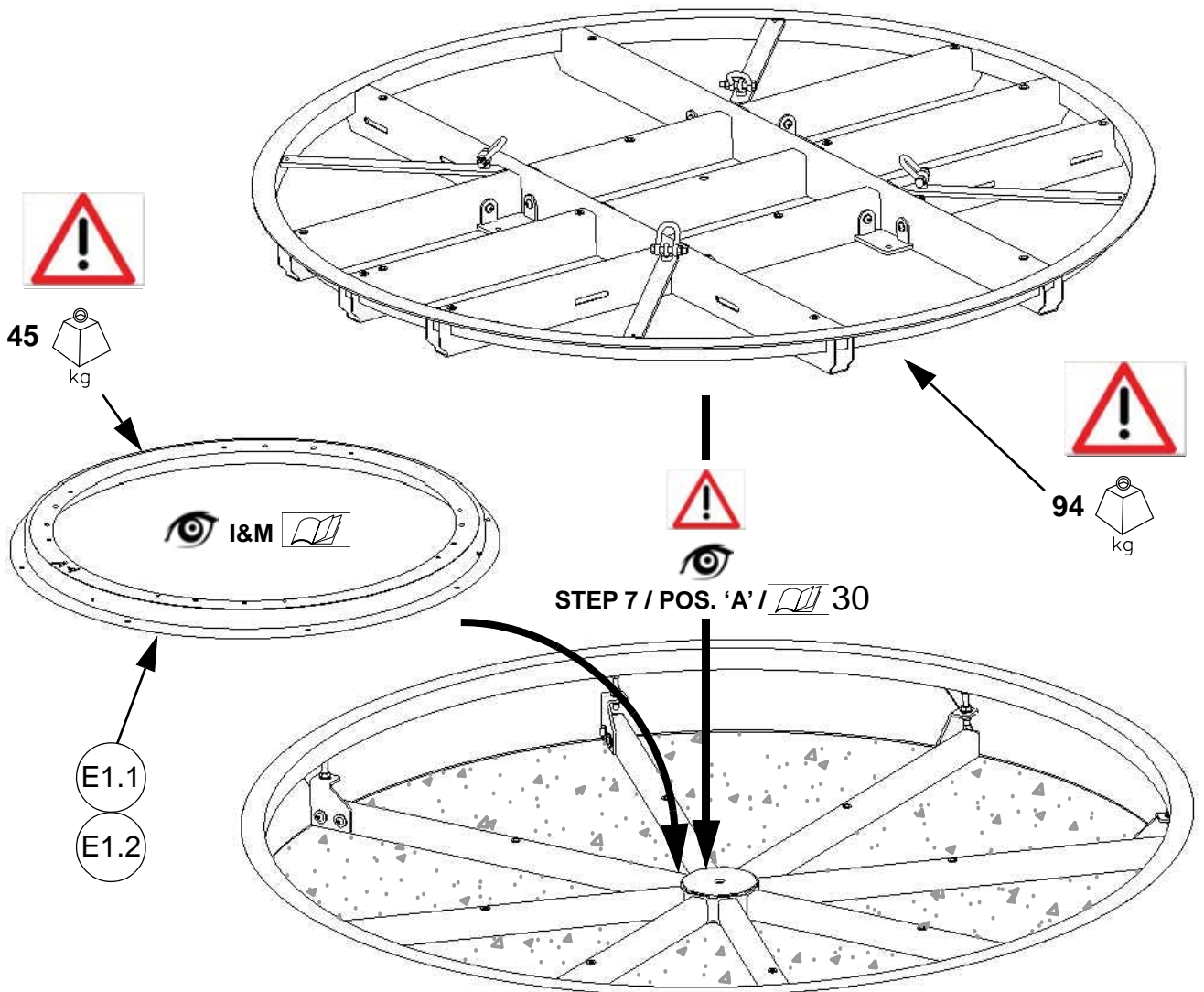
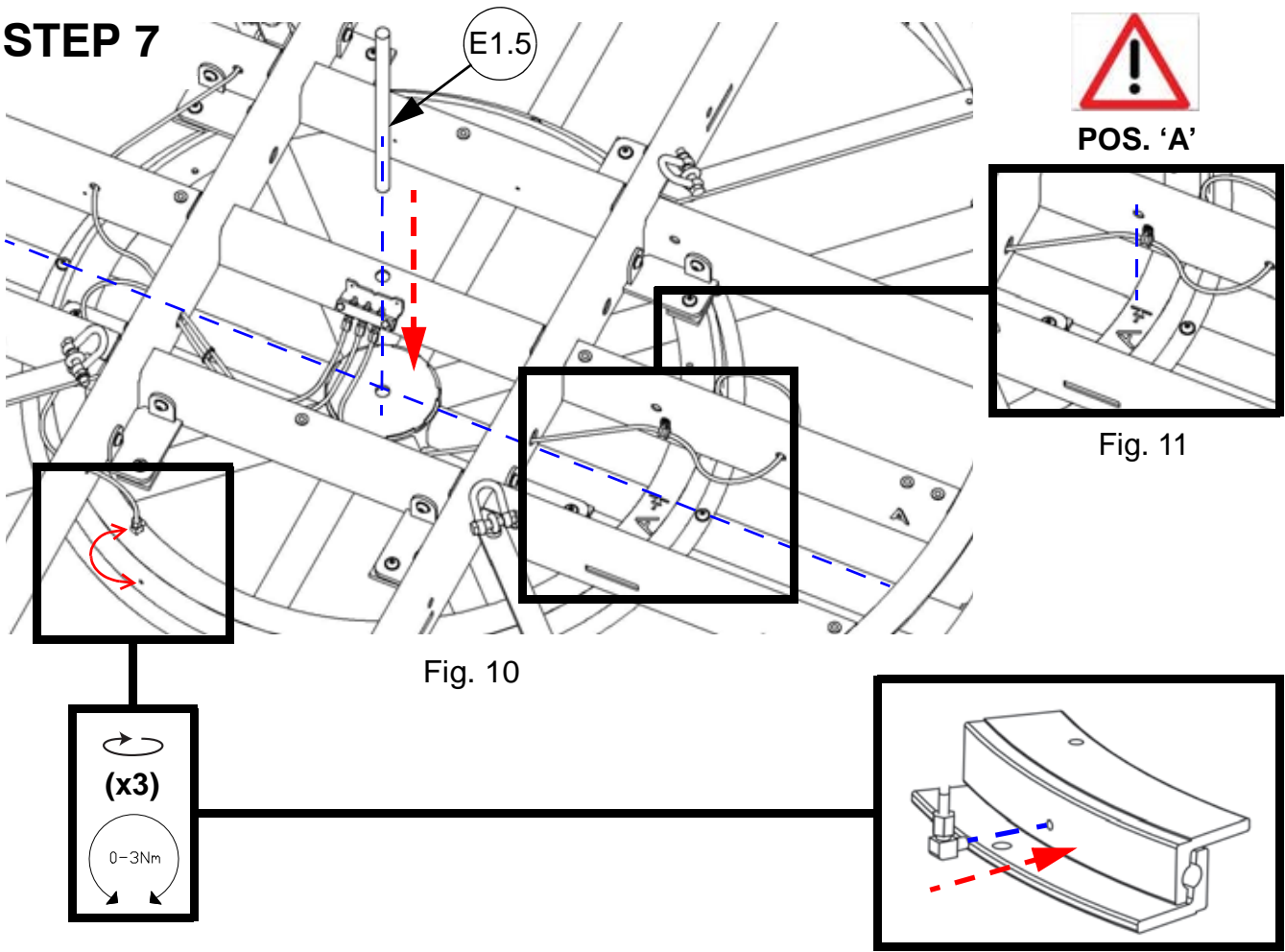
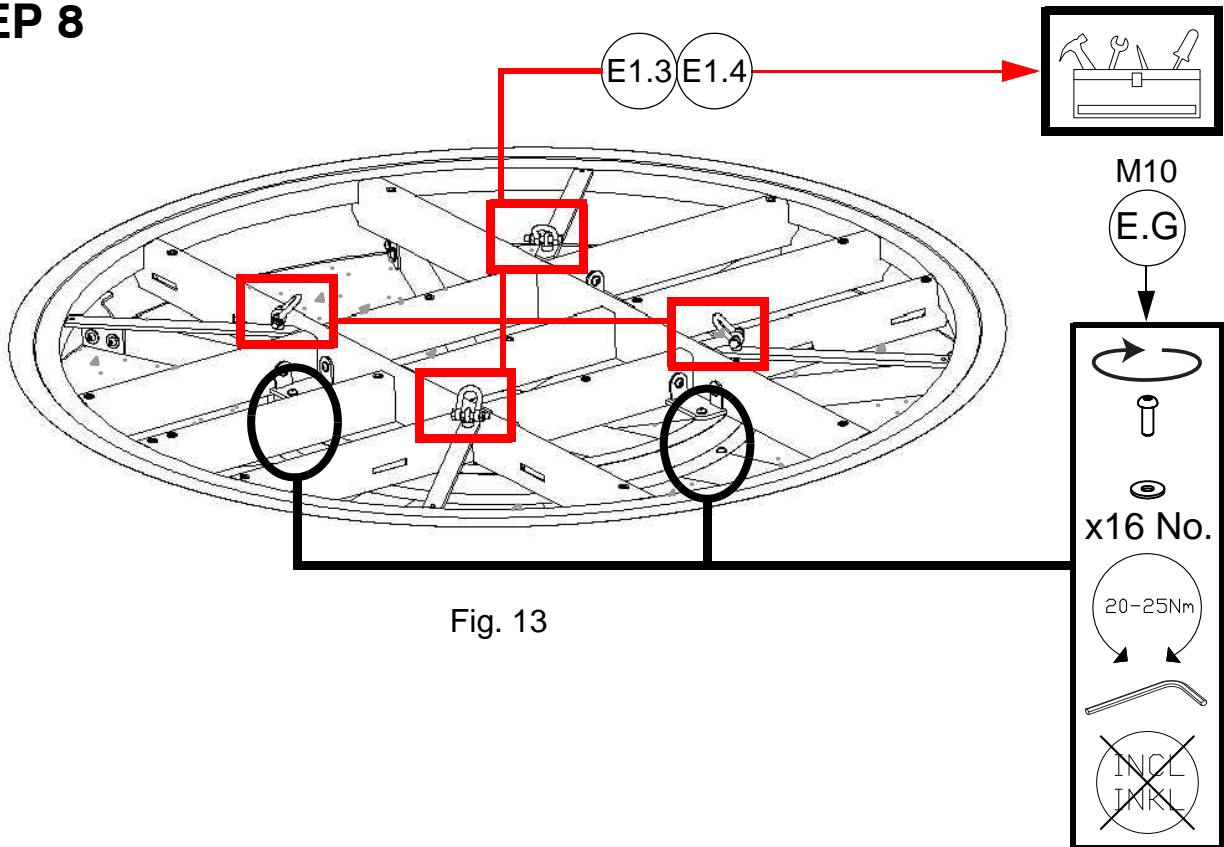

Fig. 9

STEP 7



STEP 8



STEP 9



APPENDIX C ~ STEPS 2 - 8

 17 - 20

STEP 10

REF.	QTY.
E.A	27
E.B	6
E.C	1
E.D	21
E.E	1
E.F	2
E.G	16

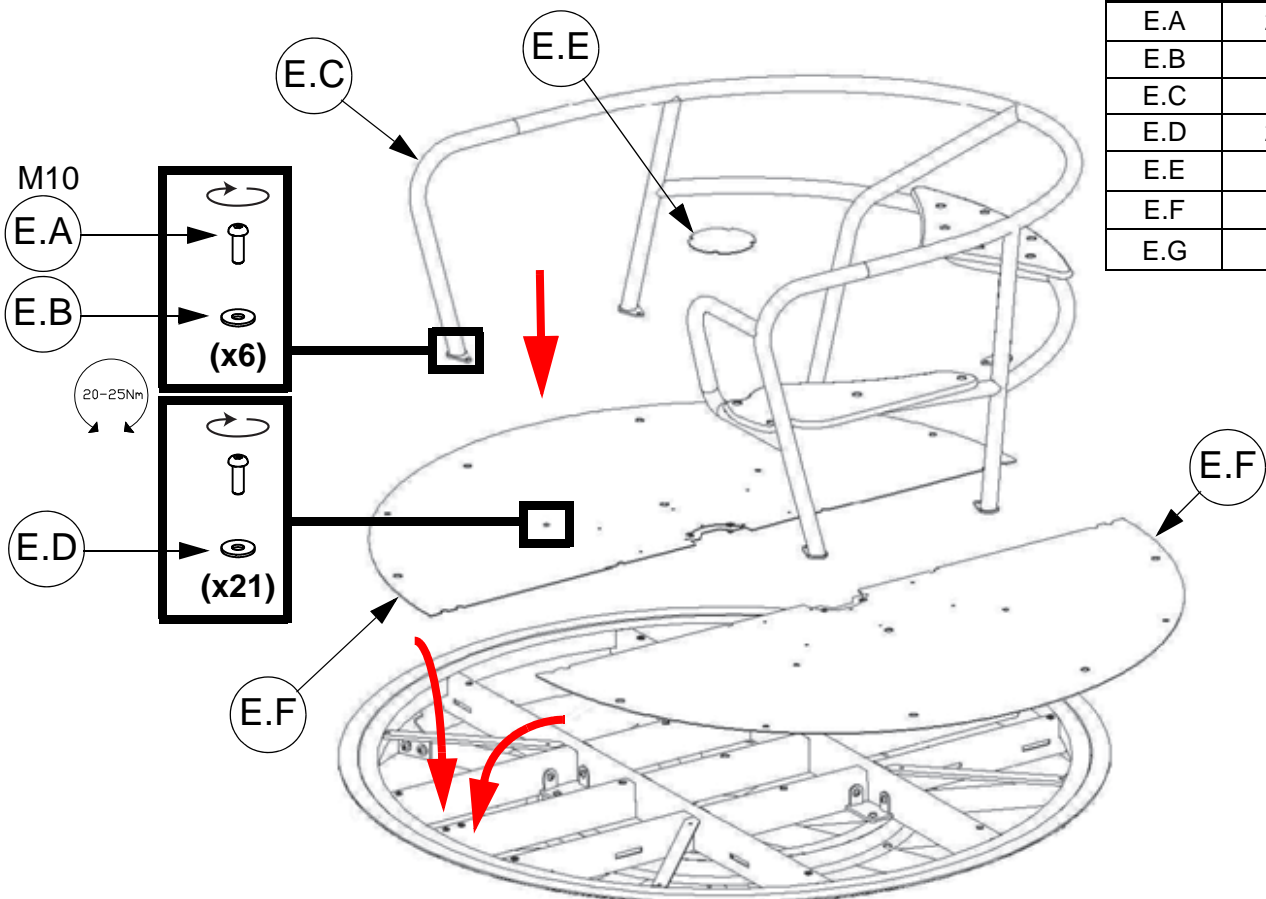

Fig. 14

